



IMAGE: A MAP OF THE STARS OF THE ORION CONSTELLATION

Print ISSN: 2514-863X Online ISSN: 2514-8648

# JournalPreview

London Journal of Research in Computer Science and Technology  
Volume 19 | Issue 1 | Compilation 1.0



# JournalPreview

LONDON JOURNAL OF RESEARCH IN COMPUTER SCIENCE AND TECHNOLOGY

This document is a pre-published view of London Journal of Research in Computer Science and Technology Volume 19, Issue 1 and Compilation 1.0. For any minor changes and updations kindly follow your paper's live editing URL given in sent email or get in touch with our support team at [support@journalspress.com](mailto:support@journalspress.com) or visit our website to use live chat support. This is a beta document thus order, content or existence of papers may alter in the published eJournal. You are requested to kindly acknowledge and approve your research paper in this JournalPreview within three days.

# Journal Content

In this Issue



- i. Journal introduction and copyrights
  - ii. Featured blogs and online content
  - iii. Journal content
  - iv. Curated Editorial Board Members
- 



- 1. Enhancing the Customer's Centricity through Web...  
**pg. 1-7**
- 2. Global Trends in Cyber Security  
**pg. 9-19**
- 3. Improved Oil Recovery vs. Enhanced Oil Recovery  
**pg. 21-28**
- 4. Animation and Games Computer Design to Build...  
**pg. 29-36**
- 5. A Quantitative Technique for Systematic Monitoring of the...  
**pg. 37-46**
- 6. Performance Analysis of Dispersion Compensation...  
**pg. 47-55**



- 
- v. London Journals Press Memberships



Scan to know paper details and  
author's profile

# Enhancing the Customer's Centricity through Web Analytics 2.0

*Muna Fayyadh*

*Colorado Technical University*

## ABSTRACT

This paper introduced an overview of Web analytic 2.0 and the BI tools that used to improve the marketing performance by attracting the target customers to their websites, BI tools used to help the managers in growing their business through different ways. This paper presents a background of this topic, in addition to the main problem that faces the new commercial. The purpose of this study is also existing here along with the Web analytic process methodology, including the way used to define the goals, metrics, gathering and analyzing the required data for this process. The study significance shows the effect of applying Web analytic 2.0 which offers the companies metrics schemes to measuring the digital marketing performance.

*Keywords:* NA

*Classification:* 2.0 H.3.m

*Language:* English



LJP Copyright ID: 975721  
Print ISSN: 2514-863X  
Online ISSN: 2514-8648

London Journal of Research in Computer Science and Technology



Volume 19 | Issue 1 | Compilation 1.0

© 2019, Muna Fayyadh. This is a research/review paper, distributed under the terms of the Creative Commons Attribution-Noncommercial 4.0 Unported License <http://creativecommons.org/licenses/by-nc/4.0/>), permitting all noncommercial use, distribution, and reproduction in any medium, provided the original work is properly cited.

# Enhancing the Customer's Centricity through Web Analytics 2.0

Muna Fayyadh

Doctoral Student at Colorado Technical University Information Assurance.

## ABSTRACT

*This paper introduced an overview of Web analytic 2.0 and the BI tools that used to improve the marketing performance by attracting the target customers to their websites, BI tools used to help the managers in growing their business through different ways. This paper presents a background of this topic, in addition to the main problem that faces the new commercial. The purpose of this study is also existing here along with the Web analytic process methodology, including the way used to define the goals, metrics, gathering and analyzing the required data for this process. The study significance shows the effect of applying Web analytic 2.0 which offers the companies metrics schemes to measuring the digital marketing performance.*

### *Opportunity/Problem Statement*

This study addresses the opportunity to define, identify, and attract targeted customers to the business 'website for increasing the revenue, business profitability, and business performance. Business Intelligence processes and tools can be used to this.

### *Purpose Statement*

The purpose of the research is to: prove the use of BI in identifying the target customer profile, revisit the goals and recognize the metrics that support to measure the achievement of business channels. This process can be complete by using Web analytics 2.0 which offers organizations metrics systems to measure digital marketing performance. Web Analytic can be optimistic as the act of growing a website persuasions and relevancy to accomplish higher conversions rate.

### *The significance of the Study*

In this study, BI has been used as a model to find the target measures, which affect the increase in the number of online customers and make business effectiveness. BI can be used to recognize the target customer and rise the number of users who are visiting the websites. Web analytics can give the managers a good insight into how the site is serving the users to meet their requirements (Turban et al., 2013). It helps in increasing the response rate by dealing with the right customers, which in turn will increase the Return on Investment (ROI) and increase the customer's loyalty. Having a completely advanced and attractive website without any web analytic software programs is totally useless (Stone, 2009). This study is a way to improve the online marketing plan to make more leads to the sites. This study will help to track the kind of data and find out the best promotion method works for the business to plan the marketing strategy (Järvinen & Karjaluo, 2015).

### *Justification statement*

The Web analytics is significant to analyze the web data and make the best use of the site (Waisberg & Kaushik, 2009). Web analytics measure things that are considered by the webmaster. The reason to select this topic comes from the experience of working with customers for several years as a practical support for solving the technical issue in business websites and CRM software (Weber, 2009). In this paper, the BI tools have been used to increase the target customers and the target people to their business. Web analytics tools can be used to bring those customers to visit the websites and purchase their

products (Pate, 2010). Web analytics will help to advance the performance of the website. It also assists to measure the efficiency of an advertisement campaign, that will increase the revenue and profitability (Hughes, 2016).

*Author:* Colorado Technical University.

## I. INTRODUCTION TO WEB ANALYTICS 2.0

### A. Background of Web analytics 2.0 and BI

Web Analytics is the science that improves the websites in order to grow the business success by refining the user's websites experience (Waisberg & Kaushik, 2009). This science uses statistic, data mining technique, and procedural processes (Nakatani & Chuang, 2011). It is an art because, like brilliant painters, the analyst has to get from a varied pallet of data resources to find the goal that will produce insight. It is also an art since redesigning the website needs deep levels of originality, matching user-centric scheme, promotion, contents, pictures, and more. Also, the analyzer is always walking the acceptable line between the website designers, IT workers, vendors, senior management (Waisberg & Kaushik, 2009). For business success, it is important to understand what the customers are looking for, it gives the managers better ideas of who they are, how they act, how they segment the keywords and link it to how the managers are segmenting (Cleary, 2013).

### B. Moving to Web Analytics 2.0

Powered by the integration of big data, the cloud computing, and the new analytical approaches, analytic 2.0 delivers a new insight into advertising's outcome on revenues (Nakatani & Chuang, 2011). It includes three broad activities: attribution, the processes of measuring the contribution of the elements of advertising; optimizations, by using projecting analytics tool to run scenario for businesses planning; and allocations, the real-time redeployment of resource across advertising activities based on the optimization scenario.

## II. RESEARCH METHODOLOGY

### A. Applying Web Analytics Procedure to Advance the users Experience

The goal of Web Analytics is to understand and advance the experiences of online clients while growing incomes for online business. Compared to other methods, this can be complete by learning the ways clients navigating the websites (Nakatani & Chuang, 2011). The official meanings of Web Analytics are the measurements, collections, analysis, and broadcasting of internet information for the determinations of sympathetic and enhancing Web usages (Waisberg & Kaushik, 2009). Web Analytic is not a technology to get a report; it is a procedure that offers some good cycles for websites optimizations (Phippen et al., 2004). According to the field's best practice, the procedure will allow websites owners to measure customer's gaining costs against incomes, to get the most gainful visitors are acting in the websites, and to enhance the websites and advance its performance or effectiveness. The important steps of this process are the following (Waisberg & Kaushik, 2009):

#### 1- Defining the Aims of web analytics process

The response to the inquiry is critical and important to a website's aims: why does the Website exist? The Website will have a single response to the question: for instance, the e-commerce Websites must sell goods, web supporters must answer the clients' question, and must deliver satisfied service (Phippen et al., 2004). The website's owners must describe success giving to his/her own objects and revisit the aims occasionally. The website's purpose is a serious issue that can help in classifying the metric that assists to determine the achievement of these channels (Waisberg & Kaushik, 2009).

#### -Defining the Website Metrics by Key Performance Indicator (KPIs)

Calculating the goal's achievement will be done by making a Key Performance Indicator (KPI). It is a knowledge in the Web Analytic communities that data does not worth the gathering if it does not

produce insights (Nakatani & Chuang, 2011). If the advertising costs per visitors to the websites are measured, there must be two movements connected to it: one for the declines in this numbers, and one for a growth in it (Waisberg & Kaushik, 2009). The important feature of the KPI is extremely adaptable: each business, division, or individual should have its KPI well-defined based on the business or individual objects and interest. One shared division of KPIs crossways the industries is by order: upper-management obtains reports on the general achievements of the website's goals; mismanagement obtains reports on campaign and site optimizations result; and specialists obtain thorough and practical reports on websites performance (Waisberg & Kaushik, 2009). Good KPIs should cover four points:

- a. *Un-complex*: Selections in business are made by persons in numerous sections with dissimilar backgrounds. If the web forecaster was understanding the KPIs, it is improbable that decisions makers crossways the business will use it (Waisberg & Kaushik, 2009).
- b. *Relevant*: Each commercial is sole, even industries that appear like they might be in the same businesses. It must be supposed that businesses should/would/could amount their websites with comparable web metric (Waisberg & Kaushik, 2009). Though, the only object they have in sharing is the detail that they retail large-screens TVs on their websites. Everything else is dissimilar: their commercial model, their urgencies, and how each incline to use the Web in its multi-channels portfolios.
- c. *Timely*: Countless metrics should be providing prompt so that decisions makers can make a timely decision. Even outstanding KPIs are unusable if it takes a month to get data when the industries change every period (Waisberg & Kaushik, 2009).

### 3- Collecting the Required Data for Web analytics platforms

It is known that information is composed precisely and protected on local or outside

databases for additional analysis (Waisberg & Kaushik, 2009). Data collections are central to analysis outcomes. Some key ways of taking data activities from the website include: WebLog, each time the visitors to websites need data (for instance, when the visitor clicks some links to go to other pages on the websites); the servers of the site register this demand in log files (Turban et al., 2013). The log files can have numerous formats which are important to keep the IP of the computer that requests the information, dates or time at which the transactions were accomplished, time is taken for transactions achievement, bytes moved, and whether the cache hit happened (Waisberg & Kaushik, 2009).

When start tracking where the web visitors are spending the time and how they find the websites, it is easy to understand the keywords and contents that managers need to make their websites more effective (Turban et al., 2013). This analytic will tell the managers if they are on the right tracks and where they may need to use innovative keywords and add new contents (Phippen et al., 2004). Web analytics also important to enhance the customer-business relationship, some key components include.

a. *Web Log*: As discussed the previous paragraph, the advantages of this technique includes: the owners have full controls through the confidentiality of the data; Weblog is available backward, which enable the websites owners to reanalyze pasts campaign and reprocess data; It saves web flatterer behaviors (crawlers from search machines visits the websites to indexing them and demonstrate in research result) (Waisberg & Kaushik, 2009).

b. *JavaScript Taggings*: which contains a small JavaScripts (that is not allowed to be hidden) in all pages of the websites. Every time the visitors use the pages, these JavaScript is triggered, and the visitor's data information and action are protected in the separate files (Phippen et al., 2004). Advantage of this technique includes totals each visit (except the customers closes the pages before the scripts are loaded) to the websites,

while log file can be pretentious by the cached page by the Proxies (the networks connection providers) or the user's browsers, which can guide the pages to visitors without registration log files in the servers (Waisberg & Kaushik, 2009). The cache data is lost when analyzing the log file, dropping the accurateness of the customer's data. The JavaScripts are not read by the crawler, which generates a high amount of traffics and is not illustrative of customers behaviors.

c. *Web Beacon*: This tool used to check the banners impression, it is not used frequently. The web beacon can still be initiated on the webs. The great benefits (and shared usages) of web beacons is in following customers behaviors across many websites (Ahmed, 2013). It responses to the question of how excellent ads execution across numerous website is. Due to the same servers that are gathering the data, read the cookies the track them, it is easy for promoters to track, anonymously, the same visitors across the multiple places or diverse visitors to the same sites (Waisberg & Kaushik, 2009).

4- Analyze the data to comprehend the customer's behaviors

From the collected information, the web predictor should track a few initial steps. To identify analyses that will help with the conversions of data into insight, which will be vital for enhancing any websites. First, starting from the basics of any web analytics tools presenting the summary reports, the groups of basic metrics that are available directly after logging into the tools. Second, understand the traffic Source another standard report on Web Analytic tool is the traffic source reporting (Waisberg & Kaushik, 2009). It typically illustrates the percentages and absolute numbers of visitor that originated from each kind of sources. Previously, the manager of the website could select their landing page for each campaign and have the extra of determining how the companies would starting their calls to the websites. Today, this switch is lost.

The site overlay number, metric, and spreadsheet are still crushing. The users need to see the

information is visually characterized (Chen et al., 2012). The sites linked the reports, presenting in the most web analytics tool, demonstrating the numbers of clicking on each link on the pages (Ahmed, 2013). Web analyzers should look for a cluster of heavy click, the top 2 or 3 most snapped link; then try to settle this knowledge in contradiction of link that s/he is wanting the visitor to click on (Turban et al., 2013). The person must also look at the link that eventually drives the high conversion and ask a question such as do more persons converting on the sites if they are clicking on products comparisons on the homepages or go straight to a product page? It is serious to following the couples of heavy clicking and see what persons do. The web analyst tends to an emphasis on visitors, parameter, and nuances, except outcome (Ahmed, 2013). Web analyst must be pushing themselves to discovery the "critical few" significant metric for the 'sites. Also, they usually linked to the general objectives of the presence of the website. For some blogs, it can be the amount who was visiting the speaking engagement pages and attending one of the engagements (Liautaud & Hammond, 2000).

## B. Experimentation and testing

The job of the web analyst is to describe how creating, designing and implementing the idea of equality. The most stimulating outcomes about testing are not the final consequence; it is the knowledge experience of the customers (Nakatani & Chuang, 2011). The web expert, designers, and website managers will understand from the sources what the 'sites should look like, what the customer want. Using statistical techniques, one can control whether variations on the websites have enhanced the conversion rates or not. It is serious to understand that testing is not restricted to landing the page or campaign. It should be applied across the websites, wherever guests are abandoning the websites and wherever the websites are leaving money on the tables. Some endorse the following to starting and innovative web analysts (Turban et al., 2013):

1. Starting with a radical A/B tests: these shows the values of testing faster since the analyst will get the important modify faster. It will bring the expressive change essential to hold testing across the organizations.
2. Testing the Single Page vs. Multi-Pages Checkout: one of the greatest methods to advance change is to decrease Cart and Checkout Abandonments rates. Some website has one-page checkout processes: shipping, promoting, reviewing and submitting. Another website has it on many pages.
3. Optimizing the Number of ads and Layouts of ads: for 'sites portion advertisement, experts indorse testing the numbers of ads on the pages. We have seen a test in which a client reduced the number of ads on the pages by 25 percent, and the consequences enhanced by 40 percent.
4. Test multiple Pricing/Selling tactic: the following is the case study that best clarifies this method, the company was selling some products but the atmosphere got rough, so the participants got competitive(Ahmed, 2013). How to be fighting back? Some "genius" in the business had the ideas, its ok to give the cheapest products, now valued at 15 Dollars for free? This impression certainly introduces some fundamental challenges: no one enjoys giving up the revenues (Ahmed, 2013). And the employees concerned about how definite it would be, what will be the incomes influence? And they measured for risks by doing a 95 percent control and 5% versions A test.

### C. Voice of the Customer

As the webs are evolving, and the customer takes up the wheels of it, the marketer must find the solution to engage the customer with their website/brand (Ahmed, 2013). The customers are no longer pleased with consumptions; they gradually supposed to be complicated in the productions of what they buy, revolving them into prosumer. When the customers come to the websites, s/he is perhaps observing for something: to buy the products, to collect information, to have a fun, and so on. By

examining clickstreams data, it is tough (if probable at all) to comprehend whether the visitors found whatever s/he was observing for and how productive was the websites experiences (Ahmed, 2013). The most creative way to comprehend the customer is to give them the voices, ask them.

Today, it is conceivable to do a modest online survey and get significant customers feedbacks on the website's performance; 4Q Online Survey ([www.4qsurvey.com](http://www.4qsurvey.com)) deliver such a free platform(Nakatani & Chuang, 2011). The organizations will learn what transports customer to the websites, and how/if the business is bringing it (Nakatani & Chuang, 2011). 4Q suggests a four- inquiry surveys that should be requested of every customer (% of them) pending to the websites(Turban et al., 2013):

- What is the visitor on my website to do?
- Are they implementing what they setting out to do?
- If no, why?
- How pleased are the website's visitors? If the webs analyst requests to classify how best to recover the website's page using 'site-levels feedbacks, there are free options for that, Kampyle ([www.kampyle.com](http://www.kampyle.com)), a business that delivers feedbacks, analytic customer, telling us what the business does is the first stage and best method to recover customer satisfaction and, thus, websites performance (Nakatani & Chuang, 2011).

### III. FUTURE WORKS

In talking to several vendors, salespersons, website owner and management, it is clear that Web Analytic can be hard as climbing the Mount Everest. Though to be the top, one has to jump, and the best method is by creating one step a time and viewing website improvements along the way (Nakatani & Chuang, 2011). Many analyses showed that some methods can be used to advance websites performance, but considerable stakeholder the significance of Web Analytic is important in implementing change(Turban et al., 2013). Web analyst must try to get everybody in

the organizations happier about using the data, make it attractive. Surprising the people is important, staffs are always observing for ways to resolve their problem. Receiving a hundred spreadsheet packed with data does not solve the problem. One way to assist workers is to casually method them and try to comprehend their data wants (Turban et al., 2013).

#### IV. CONCLUSION

The most important question here is how can the website's managers persuade surfers to buy the products? The answer should be looking on the info and understanding what is occurring in the websites, listening to customers and their requirements and optimizing the sites to better serving; after all, they are the reasons for the presence of the site. The customers must tell the company what to perform, not a consultant, friend or feeling; the data and online survey are the places to look for customer requirements and needs. In the future, it is vital to discuss the significance of extra sources of information to understand the customer behaviors and the general websites capability as comparing to a competitor. It is a new suggested method to think about the web info and the best designs to meet the customer requirements, a new approach to think about the original resources of information, which can build the complete pictures of customers and their behavior in website, to attract the customers to buy the products and increase the profitability.

#### REFERENCES

- Ahmed, S. (2013). *Towards a utility framework for enterprise business intelligence mashups* (Order No. MS26761). Available from ProQuest Dissertations & Theses Global. (1522752067). Retrieved from <https://proxy.cecylibrary.com/login?url=https://search-proquest-com.proxy.cecylibrary.com/docview/1522752067?accountid=144789>
- (This resource describes the best use of enterprise BI as a framework mashups in different kinds of business)
- Cleary, P. J. (2013). *Main street 2.0: A guide to online and social media marketing for small business through the use of online analytics and content marketing strategies* (Order No. 1540509). Available from ProQuest Dissertations & Theses Global. (1418021294). Retrieved from <https://proxy.cecylibrary.com/login?url=https://search-proquest-com.proxy.cecylibrary.com/docview/1418021294?accountid=144789>
- (This resource used to get more information regarding the online analytics tools and marketing performance, this helps to add info in the topic overview)
- Chen, H., Chiang, R. H., & Storey, V. C. (2012). Business intelligence and analytics: from big data to a large impact. *MIS Quarterly*, 1165-1188.
- (This resource is useful to get more info regarding the BI analytics)
- Hughes, M. E. (2016). Entrepreneurship in a web 2.0 world: Factors influencing intentions to adopt web 2.0 social media in U.S. entrepreneurial activities (Order No. 10241828). Available from ProQuest Dissertations & Theses Global. (1855176897). Retrieved from <https://proxy.cecylibrary.com/login?url=https://search-proquest-com.proxy.cecylibrary.com/docview/1855176897?accountid=144789>
- Hennig-Thurau, T., & Klee, A. (1997). The impact of customer satisfaction and relationship quality on customer retention: A critical reassessment and model development. *Psychology & marketing*, 14(8), 737-764.
- (this resource has been used to find the impact of customer and relationship quality in the business performance)
- Järvinen, J., & Karjaluo, H. (2015). The use of web analytics for digital marketing performance measurement. *Industrial Marketing Management*, 50, 117. Retrieved from <https://proxy.cecylibrary.com/login?url=https://search-proquest-com.proxy.cecylibrary.com/docview/1729122278?accountid=144789>
- (This resource has general information on the effect of Web analytics in marketing)

performance measure as well as the different tools for this process, used in the Methodology)

12. Liautaud, B., & Hammond, M. (2000). *e-Business intelligence: turning information into knowledge into profit*. McGraw-Hill, Inc.
  13. Pate, K. D. (2010). *Developing a framework for the evaluation of corporate non-transactional business-to-consumer websites: A descriptive study* (Order No. 3419165). Available from ProQuest Dissertations & Theses Global. (751932810). Retrieved from <https://proxy.cecybrary.com/login?url=https://search-proquest-com.proxy.cecybrary.com/docview/751932810?accountid=144789>
  14. Phippen, A., Sheppard, L., & Furnell, S. (2004). An applied assessment of Web analytics. *Internet Research*, 14(4), 284-293.
  15. (This resource has been used to evaluate the importance of applying Web analytics in the study significance)
  16. Stone, M. (2009). Staying customer-focused and trusted: Web 2.0 and customer 2.0 in financial services. *Journal of Database Marketing & Customer Strategy Management*, 16(2), 101-131. Doi: <http://dx.doi.org.proxy.cecybrary.com/10.1057/dbm.2009.13>
  17. (In this resource, the imperative benefits that can be gained from Web 2.0 analysis in customer's side, regarding the financial services)
  18. Sawchuk, K. A. (1995). Age, identity, and target marketing. *Images of aging: Cultural representations of later life*, 175.
  19. (This resource has been used to get info in regards the target marketing process)
  20. Turban, E., King, D., Sharda, R., & Delen, D. (2013). *Business intelligence: a managerial perspective on analytics*. Prentice Hall, New York.
  21. (This resource has been used to define the different viewpoints of BI analytic on Web analytics).
  22. Waisberg, D., & Kaushik, A. (2009). *Web Analytics 2.0: empowering customer*
- centricity. *The original Search Engine Marketing Journal*, 2(1), 5-11.
23. (This resource has been used to understand how the digital customers or online customers can affect the business performance).

*This page is intentionally left blank*



Scan to know paper details and  
author's profile

# Global Trends in Cyber Security

*Frankline Makokha*

*University of Nairobi*

## ABSTRACT

With the growth of Internet of Things (IoT) technology, a lot of devices are being connected and exchange information using the Internet. This increases the number of devices susceptible to cyber crimes or themselves posing as cyber attack vectors. This poses a challenge to current cyber security systems, which rely on human intervention for them to work effectively in deterring cyber crimes. This paper recommends integration of Artificial Intelligence techniques in cyber security measures both at prevention level and at investigations level.

*Keywords:* Internet of Things; Cyber Security; Critical Infrastructure; Cyber Infrastructure; Computer Forensics; Artificial Intelligence.

*Classification:* D.4.6

*Language:* English



LJP Copyright ID: 975722  
Print ISSN: 2514-863X  
Online ISSN: 2514-8648

London Journal of Research in Computer Science and Technology



Volume 19 | Issue 1 | Compilation 1.0

© 2019. Frankline Makokha. This is a research/review paper, distributed under the terms of the Creative Commons Attribution-Noncommercial 4.0 Unported License <http://creativecommons.org/licenses/by-nc/4.0/>, permitting all noncommercial use, distribution, and reproduction in any medium, provided the original work is properly cited.

# Global Trends in Cyber Security

Frankline Makokha

## ABSTRACT

*With the growth of Internet of Things (IoT) technology, a lot of devices are being connected and exchange information using the Internet. This increases the number of devices susceptible to cyber crimes or themselves posing as cyber attack vectors. This poses a challenge to current cyber security systems, which rely on human intervention for them to work effectively in deterring cyber crimes. This paper recommends integration of Artificial Intelligence techniques in cyber security measures both at prevention level and at investigations level.*

**Keywords:** Internet of Things; Cyber Security; Critical Infrastructure; Cyber Infrastructure; Computer Forensics; Artificial Intelligence.

**Author:** University of Nairobi, School of Computing and Informatics Nairobi, Kenya.

## I. INTRODUCTION

Cyber infrastructure has become one of the critical infrastructures for any economy to prosper. This is due to reliance on ICTs by all sectors of the economy.

Critical infrastructure is a collection of systems and assets both tangible and non-tangible that provide critical services to the nation [1]. Cyber infrastructure refers to computational systems, data and information management, advanced instruments, visualization environments, and people, all linked together by software and advanced networks to improve scholarly productivity and enable knowledge breakthroughs and discoveries not otherwise possible [2].

Other definitions of cyber infrastructure include: the constellation of ICT that support

communication, coordination, collaboration, and collection, storage, analysis and dissemination of data for distributed groups of researchers [3]; The comprehensive hardware for computing, data and networks, digitally-enabled sensors, observatories and experimental facilities, and an interoperable suite of software and middle-ware services and tools needed to capitalize on dramatic advances in information technology[4];.

From these definitions, cyber infrastructure can be defined as a collection of electronic and computing systems, configured to provide specific services via computer networks.

Due to the value derived from cyber infrastructure and the level of investments in them, cyber infrastructures have become a target from malicious persons out to vent their anger on regimes or persons utilizing the cyber infrastructures.

This has necessitated the development of measures to protect cyber infrastructures, called cyber security. Cyber security is the collection of tools, policies, security concepts, security safeguards, guidelines, risk management approaches, actions, training, best practices, assurance and technologies that can be used to protect the cyber environment, organization and user's assets [5].

The measures that have been put in place to mitigate against or deter the occurrence of cyber crimes are collectively referred to as cyber security.

Cyber crimes refers to computer-mediated activities which are either illegal or considered illicit by certain parties and which can be conducted through global electronic networks [6].

Other definitions of cyber crime include: crimes in which computer networks are the target or a substantial tool [7]; acts against the confidentiality, integrity and availability of computer data or systems represent the core of cybercrime [8].

Investigation of cyber crime requires acquisition of evidence from digital devices through Computer Forensics. Computer Forensics is the use of specialized techniques for the preservation, identification, extraction, authentication, examination, analysis, interpretation and documentation of digital information, while Forensics is the application of investigative and analytical techniques that conform to evidentiary standards used in or appropriate for a court of law or other legal context [9].

Computer forensics could also be referred to as: the science that is concerned with the identification, collection, examination and analysis of data during an investigation [10]; The application of computer science and investigative procedures for a legal purpose involving the analysis of digital evidence (information of probative value that is stored or transmitted in binary form) after proper search authority, chain of custody, validation with mathematics (hash function), use of validated tools, repeatability and possible expert presentation [11].

## II. FORMS OF CYBER CRIME

Cyber crime takes three main forms depending on the target, namely: cyber crime against persons/entity; cyber crime against institution; and cyber crime against computers and its associated infrastructures [11].

Cyber crimes could also be classified into four classes as: offences against the confidentiality, integrity and availability of computer data and systems; Computer-related offences; Content-related offences; and Copyright-related offences [12].

### 2.1 Cyber crime against persons

These are the most common forms of cyber crime and include: cyber stalking/bullying, cyber defamation, email spoofing, identity theft, Phishing, password sniffing.

### 2.2 Cyber crime against institutions

These are criminal activities targeted at certain institution e.g. financial institutions, academic institution or government bodies. They include compromising the Confidentiality, Integrity and Accessibility of the information held by those institutions e.g. systems hacking, intellectual property (software piracy, copyright infringement, trademark violations, theft of computer code) and Distributed Denial of Service (sabotage).

### 2.3 Cyber crime against Computers and associated Infrastructure

These are criminal activities targeted at computer infrastructures in general without targeting any specific person, entity or computing systems. They include computer virus creation, cyber vandalism.

## III. MOTIVATIONS FOR CYBER CRIME

The motivation for cyber crime can be understood through analysis of the groups of persons engaged in the cyber crime.

The persons involved in cyber crime could be categorized as: the idealist, the greed motivated (criminals) and the cyber terrorist [11].

The idealists are normally teenagers, seeking social recognition and pleasure by deriving satisfaction in successfully challenging existing cyber security measures in place.

The greed motivated, the typical cyber criminals, are money motivated persons, ready to sabotage cyber security measures for monetary gains.

The cyber terrorists are usually a group of individuals out to sabotage cyber security measures for purposes of supporting a given cause they defend or due to disgruntlement with

government policies. It is also called cyber warfare.

## VI. TRENDS IN CYBER CRIME

Computer crimes date back in the 1960s [13]. Computer crimes in this era involved physical damage to computer systems and subversion of the long-distance telephone networks crimes.

The crimes later evolved to sabotage of computer systems in the 1970s. This took the forms of intentional power systems shutdown and cable cuts. The Late 1970s saw the emergence of impersonation after credentials stealing from social engineering tactics like dumpster diving amongst other tactics. This later transformed to credit card frauds in the 1990s.

Technological advancements in the 1990s led to the emergence of hacking as a computer crime. The main target of this crime was banks where client money could be transferred without their consent and knowledge. This evolved to Salami Attacks, where money in small negligible and not easily detectable was moved from bank accounts.

The 1990s and early 2000s saw the prevalent of malwares from viruses, logic bombs, Trojan horses and worms. This could be used for various vices including confidential information gathering, alteration, destruction, spamming and denial of service.

The mid 2000s saw the emergence of malicious botnets. A bot is a script or sets of scripts designed to perform a predefined function in an automated fashion [14]. The same author defines a botnet as networks of infected end- hosts, called bots that are under the control of a human operator commonly known as a bot master/ bot herder.

The botnets are used for various cyber crimes namely launching Distributed Denial of Service (DDoS) attacks, spamming, sending Trojan and phishing emails, illegally distributing pirated media and software, force distribution, stealing information and computing resource, e-business

extortion, performing click fraud, and identity theft for financial gain [15,16].

By 2013, Cyber crime had taken the form of ransomware. Ransomware is a type of malware that stops or limits users from accessing their system, either by securing the system's screen or by locking the users' files unless a ransom is paid [17].

Examples of common Ransomwares include Cryptolocker, Cryptotwall, Locky and TeslaCrypt. The ransom is normally paid in form of bitcoin [17].

The latest cyber crime model is cybercrime as a service (CaaS). This refers to provision of services to others to facilitate their commission of cyber-crimes [18].

The various services available on CaaS platforms include: Research as a Service (Legal or illegal collection of information on victims); Infrastructure-as-a-service (Hosting of malware on secure networks, Rental of established botnets for Distributed Denial-of-Services, Cloud-based computing power for operations; Crimeware-as-a-service (Design and delivery of customized crime solutions); Hacking-as-a-service (Outsourcing of a complete cyber-enabled attack and Technical support for cybercrime activities) [19].

These development of a “as-a-service” innovations have accelerated the evolution of the cybercrime ecosystem and the growth of the cybercrime business, reconstructing into a specialization, commercialize, and cooperation system [20].

A summary of the trends in cyber crime is as shown in figure 1.

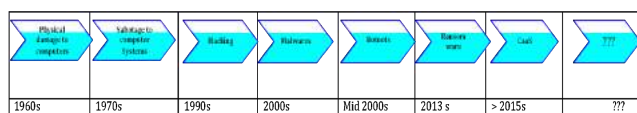

Figure 1: Trends in Cyber crime

## V. MEASURES IN PLACE TO COUNTER CYBER CRIME

The advancements in cyber crime have evolved hand in hand with measures of fighting cyber crime. These measures can be categorised as: physical measures, technological measures and collaborative frameworks.

The physical measures aim to address access to cyber infrastructure by implanting access control features ranging from physical barriers to unauthorised access, biometrics and human guards.

Technological measures include rapid development of Anti virus, Firewalls, Intrusion detection systems and Intrusion Prevention systems.

Collaborative frameworks in fighting cyber crimes involve setting up of computer emergency response teams that liaise with other teams globally in alerting and educating each other on latest attack vectors.

Whereas these measures have helped mitigate cyber crimes, they have limitations which impact on their effectiveness in combating cyber crime.

### 5.1 Limitations of Anti Virus and Intrusion Detection/Prevention Systems

Antivirus and Intrusion detection/Prevention systems, if not designed with care can turn from defense mechanisms to instruments of attacks [21]. Further, since most anti virus operate based on known virus signatures, unknown threats for which no signatures exist can easily bypass the detection.

Several vulnerabilities have been sported in various anti virus softwares e.g. Kaspersky [22], AVG [23], FireEye [24] and EST [25].

Anti viruses use byte patterns, hash sums and heuristics during virus signature mapping [21].

Anti virus assisted attacks are launched using malicious markers, which do not rely on

exploiting vulnerabilities but is based on the weak design of pattern-based signatures [21].

The main vulnerabilities identifiable in anti virus software are Local privilege escalation, Active –X related, Engine based and management interface related [26].

Intrusion Prevention and Detections systems can be classified based on detection methods, namely Anomaly Detection Systems, signature based detection and Decision Making Techniques [27].

These system have limitations in terms of gathering a set of static criteria of normal behaviors, how to identify new attacks with no signatures in the database and how or who makes the decisions, respectively [27].

Firewalls suffer from various limitations too, including inability to protect systems against malicious insiders and inability to protect against completely new threats [28].

### 5.2 Limitations of collaborative frameworks

Collaborative frameworks suffer from lack of secure channels to exchange cyber crime information. This raises the possibility of risk of the exchanged information falling into the wrong hands.

Cyber crimes spread at alarmingly fast rates hence delays in sharing cyber crime information renders the shared information less effective especially if the information is received after the attack has occurred.

Legal constraints that prevent sharing of experiences on going legal proceedings against cyber crime mean that law enforcement authorities are not at liberty to divulge all the facts and elements of an on going case [29].

Other major limitations include: issues surrounding trust and control of incident response; questions about obligations regarding disclosure and exposure; the evolving liability and regulatory landscape; challenges faced in the cross-border investigation of cybercrime; and

cross-border data transfer restrictions that impede the ability of companies to respond nimbly to cyber threats and incidents [30].

## VI. TOOLS USED IN DIGITAL FORENSICS

Some of the tools used in digital evidence gathering include: Encase developed by Guidance Software of USA; Forensic Toolkit (FTK) by AccessData of USA; SANS SIFT Workstation of USA; Helix3 Pro of the USA; Automated Image and Restore (AIR) developed by Steve Gibson, founder of Gibson Research Corporation [31].

Additional forensics tools include: X-Ways Forensics developed by X-ways of Germany; Virtual Forensics Computing (VFC) developed by the MD5 of the UK [33].

Others include ProDiscover by Technology Pathways of the USA; and SMART by ASR Data of the USA [34]; Belkasoft Evidence Centre by Belkasoft of the USA; Computer Aided Investigative Environment (CAINE) created by the digital forensics project of Italy; Foremost created by Special Agents Kris Kendall and Jesse Kornblum of the United States Air Force Office of Special Investigations; MemGator created by the E5h Forensic Solutions of the UK; and OSForensics from PassMark of the US [35].

Whereas several tools have been developed to aid in digital forensics they suffer from various limitations, namely: limitations in terms of the operating systems on which they can operate, limitation on the file formats they can read, limitation of the area of focus for the tool (e.g. hard disk, browser, operating systems files etc.), their effectiveness on ability to process encrypted files and ability to recover overwritten files.

Further, most tools were designed for usage on traditional computing platforms, namely desktop or laptop. In cases where the forensics are to be carried on other computing platforms, like cloud computing, edge computing, Fog Computing, mist computing, etc, then the tools will be limited if not rendered unusable.

The proliferation of big data poses a challenge to current tools since they are not optimized to analyze big data, which is varied, and moving at high velocity. The overall efficiency of current forensics tools is limited to employment of simple hashing and indexing algorithms [36].

Digital investigations are also hindered by the limited processing capabilities of human analysts, since the tools as currently designed present data to the analysts who have to evaluate it and present in report form. With big data, this becomes a challenge in terms of man hours required to evaluate and analyze the large data sets.

This limitation can be overcome by integration of artificial intelligence techniques in the tools used for digital forensics.

## VII. ARTIFICIAL INTELLIGENCE IN CYBER SECURITY

Due to the proliferation of devices connected on the internet, combined with an uptake of Internet of Things (IoT) technologies, the number of devices vulnerable to attacks or used in cyber crimes will surge, posing a challenge to existing means of fighting cyber crimes.

The rate at which new threats are being created now far exceeds the financial resource or human capability required to manually analyze or create rules for each and every new piece of malware code [37].

To cope with the high rate at which new malwares are spawned, Artificial Intelligence will come in handy. Artificial Intelligence (AI) is a field of study concerned with development of computers that are able to engage in human-like thought processes such as learning, reasoning, and self-correction [38].

Other definitions of AI are: A discipline devoted to developing and applying computational approaches to intelligent behavior [39]; machines that are capable of performing tasks that, if performed by a human, would be said to require intelligence [40]; is a subfield of computer science

aimed at the development of computers capable of doing things that are normally done by people – in particular, things associated with people acting intelligently [41]

AI therefore is a paradigm for studying, development and application of computational systems capable of perceiving and learning from their usage context, and independently applying the gained knowledge in a way a human being would apply.

### 7.1 AI Techniques

The various AI techniques include Intelligent Agents, Neural Networks and Expert Systems [42].

#### 1) Intelligent Agents

These are software components with features of intelligent behavior such as (at a minimum) pro-activeness, the ability to communicate, and reactivity (in other words the ability to make some decisions and to act) [43].

They have also been defined, as a piece of software that is situated within a given environment, where it acts autonomously, responds to changes in its environment including self recovery from failure, as it pursues its goals by assessing multiple ways of achieving the goals as it interacts with other agents [44].

Other definitions include: pieces of software that act based on information which is gathered from dynamic environment and achieve the goals successfully [44]; software entities that carry out some set of operations on behalf of a user or another program with some degree of independence or autonomy, and in so doing, employ some knowledge or representation of the user's goals or desires [45].

Intelligent agents which are able to detect unusual and malicious activities could be incorporated in Intrusion Prevention and Detection systems, in Operating systems, in Anti virus. Based on their heuristics knowledge, the agents will be able to

decide on whether to terminate or allow the activity.

A typical conceptual architecture for the integration of an intelligent agent in a host environment is as shown if figure 1.



Figure 2: High Level Conceptual Architecture of an Intelligent Agent in A host Environment

A zoomed view of the figure 1 is as shown in figure 2.

From the diagram, the agent learns the state of the environment and updates its knowledge base. Anew requested state is compared with the learned states in the knowledge base and the Beliefs (known Information about the environment), Desires (objectives to be accomplished by the agent) and Intentions (current chosen course of action) (BDIs), of the agent.

Depending on the chosen course of action, the knowledge base and the BDIs are updated accordingly. The learning process is continuous and the decisions are dynamic depending on the requested state and the BDIs

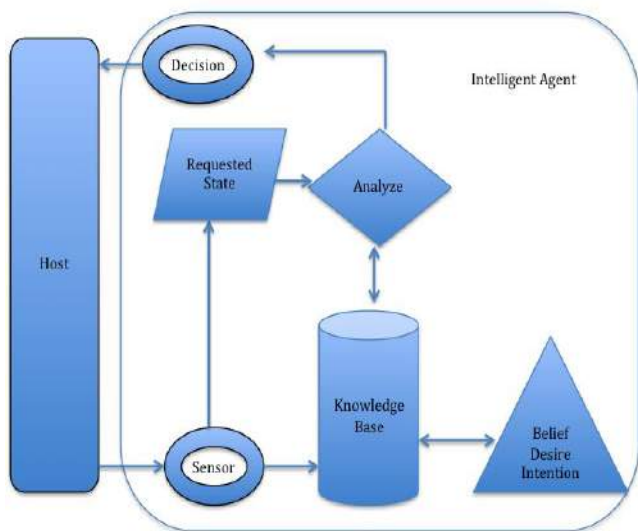

Figure 3: A zoomed High Level Architecture Diagram of An Intelligent Agent and Host Environment

## 2) Artificial Neural Networks (ANN)

ANN is a system simulating the work of the neurons in the human brain [46].

It consists of a collection of iterations to transform a set of inputs to a set of desired outputs, through a set of simple processing units, or nodes and connections between them. Subsets of the units in the iteration are input nodes, output nodes, and nodes between input and output form hidden layers; the connection between two units assigned some weight, used to determine how much one unit will affect the other. [47].

Due to the generalization feature of ANN, they are able to work with imprecise and incomplete data, meaning that they can recognize patterns not presented during a learning phase [46]. This feature is very vital in signature based detection systems.

Based on this relationship, an ANN can be used in pattern recognition and thus identify anomalies in the various computing platforms. This capability can be implemented in Intrusion Detection /Prevention Systems.

A high level architectural representation of the concept of an ANN in an IDS is shown in figure 3.

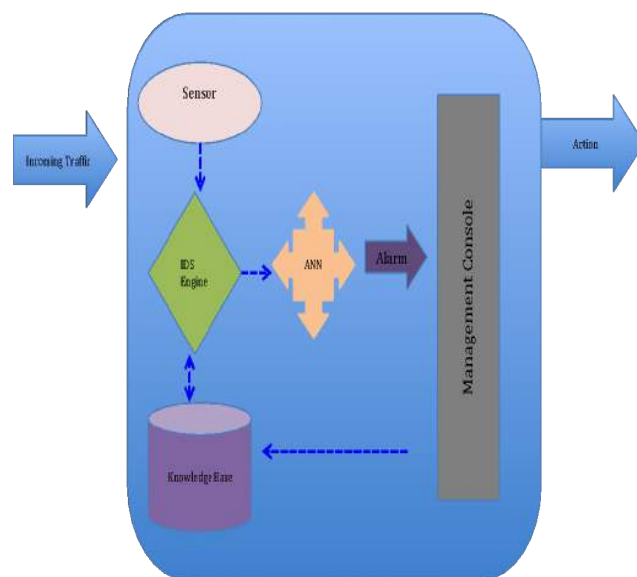

Figure 4: A high Level Architectural representation of an ANN in an IDS

From figure 3, all traffic is detected by the IDS sensor, and passed to the IDS engine, which analyses it based on the rules in the Knowledge base.

After analysis, the result is passed to the ANN, which uses that information for learning purposes. With time, the ANN will have learnt the patterns presented to it from the IDS engine, which it uses for future decision-making.

This lowers the chances of false alarms and zero days attacks from intrusions not yet configured in the knowledge base since the ANN can detect them.

Neural networks can also be extended to data encryption and used to construct an efficient encryption system by using a permanently changing key.

## 3) Expert Systems

This is a computer system that mimics the decision making of a human being [48]. They are composed of the Knowledge base which represents illustrations and assertions about the real world and the Inference Engine, which is the reasoning system.

Expert systems can take the form of Associate skilled system, which is software system for locating answers to queries in some application domain bestowed either by a user or by another software system [49].

The knowledge base could be composed of items like malicious IP addresses, known malwares, expected end system state and allowed applications.

The inference engine on the other hand could contain information on application usage patterns, geographical location of certain IP addresses.

The Inference Engine reads the current state (Knowledge) of the knowledge base, applies the rules relevant to that and asserts new knowledge in to it.

Incase a new state is required which is not contained in the Knowledge Base, the inference engine executes a set of algorithms (rules) which predict the desired state. A decision is made depending on the predicted state.

A high level architectural depiction of the expert system concept is as in figure 4.

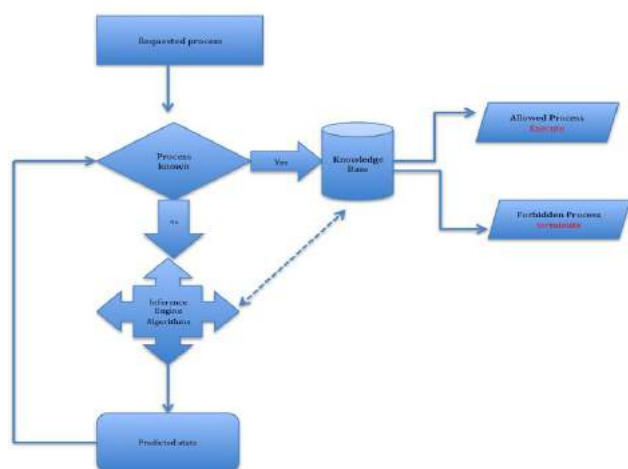

Figure 5: High Level Architecture of an Expert System Function

From figure 4, the requested process is passed through an expert system to determine whether it is a know process. If the process is known it is analyzed against the knowledge base to determine whether it is whitelisted or blacklisted.

If the requested process or state is not known, the inference engine analyzes it to determine its potential state or outcome. Depending on the outcome and system objectives, the Knowledge base is updated and the process loops back through the knowledge base for either termination or execution.

## VIII. CONCLUSION

Whereas the use of Artificial Intelligence techniques in cyber security is currently on an upward trend, there is a possibility of cyber criminals using similar Artificial Intelligence tactics to counter the fight against cyber crime.

To prevent this, this paper recommends direct integration of Artificial Intelligence techniques directly into user applications, system software as well as embedded systems. The integration will also eliminate the need for third party tools downloaded by users to fight cyber crime , which could turn out to be malicious.

Further, from the analyzed literature, AI techniques have only been used in preventing or detecting cyber crimes. AI techniques have not been used in post cyber crime activities like investigations. This paper therefore recommends explorations of ways in which AI can be applied in cyber crime investigations to reduce the reliance on human intervention in view of the proliferation of IoT devices.

## REFERENCES

1. Saadawi, T. and Colwell, J. D. Jr.(Eds) (2017) Cyber Infrastructure Protection Volume III. U.S. Army War College Press: Pennsylvania.
2. Stewart, A. C., Simmis, S., Plale, B., Link, M., Hancock, D., and Fox, C., G.(2010) What is cyberinfrastructure. In SIGUCCS '10 Proceedings of the 38th annual ACM SIGUCCS fall conference: navigation and discovery. Norfolk, Virginia, USA.
3. Kim, Y. and Crowston, K. (2012) Technology Adoption and Use Theory Review for Studying Scientists' Continued Use of Cyber-Infrastructure. Proceedings of the

- American Society for Information Science and Technology. Volume 48, Issue 1. John Wiley & Sons, Inc. :New Jersey.
4. National Science Foundation(2007) Cyber Infrastructure Vision fo 21<sup>st</sup> Century Discovery.
  5. International Telecommunications Union (2009) Understanding Cyber Crime: A Guide for Developing Countries. ICT Applications and Cybersecurity Division (CYB): Geneva.
  6. Lakshmi, M. P. and Ishwarya, T. S. K (2015) Cyber Crime: Prevention & Detection. International Journal of Advanced Research in Computer and Communication Engineering Vol. 4, Issue 3.
  7. Koops, E. J. (2010). The Internet and its Opportunities for Cybercrime. In M. Herzog-Evans (Ed.), Transnational Criminology Manual (pp. 735-754). Nijmegen: Wolf Legal Publishers (WLP)
  8. United Nations Office on Drugs and Crime, UNODC (2013) Comprehensive Study on Cyber Crime. United Nations , New York.
  9. Cartel Working Group(2010) Anti Cartel Enforcement Manual: Digital Evidence Gathering. International Competition Network (ICN).
  10. Palmer, G. (2001). A Road Map for Digital Forensic Research. Proceedings of the First Digital Forensic Research Workshop,Utica, New York.
  11. Ayofe, A. N. and Oluwaseyifunmi tan, O. (2009) Towards Ameliorating Cybercrime And Cybersecurity. (IJCSIS) International Journal of Computer Science and Information Security, Vol. 3, No. 1.
  12. Council of Europe (2001) Convention on Cybercrime: European Treaty Series - No. 185
  13. Bosworth, S., M. E. Kabay and E. Whyne (2009), eds. Computer Security Handbook, 5th Edition, Volume I. New York: Wiley.
  14. Tyagi , A. K. and Aghila, G.(2011) A Wide Scale Survey on Botnet. International Journal of Computer Applications (0975 – 8887). Volume 34– No.9, November 2011
  15. Massi, J., Panda,S., Rajappa, G., Selvaraj, S. and Revankar, S.(2010) Botnet Detection and Mitigation, presented on *Proceedings of Student- Faculty Research Day, CSIS, Pace University* , May 7th, 2010.
  16. Feily, M., Shahrestani, A. (2009) A Survey of Botnet and Botnet Detection, *3rd International Conference on Emerging Security Information, Systems and Technologies*, 2009. Athens, Glyfada, Greece.
  17. Fasheem, S. M., Kanimozhi, P. and 3AkoraMurthy, B. (2017) Detection and Avoidance of Ransomware. *International Journal of Engineering Development and Research*, Volume 5 Issue 1.
  18. Zheng, Y., Chaudhry, A. (online) Cyber crime as a Service. CaaS Analysis Report. [https://www.eecs.yorku.ca/course\\_archive/2016-17/W/3482/Team15\\_CrimeAsService.pdf](https://www.eecs.yorku.ca/course_archive/2016-17/W/3482/Team15_CrimeAsService.pdf) (accessed on 03<sup>rd</sup> July 2018).
  19. Standard Chartered Bank(online) Cyber Crime as a Service. [https://www.sc.com/fightingfinancialcrime/av/SCB\\_Fighting\\_Financial\\_Crime\\_Deep\\_dive\\_Cybercrime\\_as\\_a\\_Service\\_August\\_2017.pdf](https://www.sc.com/fightingfinancialcrime/av/SCB_Fighting_Financial_Crime_Deep_dive_Cybercrime_as_a_Service_August_2017.pdf) (accessed on 4<sup>th</sup> July 2018).
  20. Huang, K., Siegel, M. and Madnick, S.(2017) Cybercrime-as-a-Service: Identifying Control Points to Disrupt. *MIT Interdisciplinary Consortium for Improving Critical Infrastructure Cybersecurity*, MIT-(IC)3. Vol. 1, No. 1, Article 1, November 2017.
  21. Wressnegger, C., Freeman, K. , Yamaguchi, F. and Rieck, K. (2016) From Malware Signatures to Anti Virus Assisted Attacks. Computer Science Report No.2016-03, Institute of System Security, Technische Universität Braunschweig.
  22. Ormandy, T. (2015) Kaspersky: Mo unpackers, mo problems. <http://googleprojectzero.blogspot.de/2015/09/kaspersky-mo-unpackers-mo-problems.html>, 2015 (accessed on 10<sup>th</sup> July 2018)
  23. Ormandy. T.(2015) AVG: "Web TuneUP" extension multiple critical vulnerabilities. <https://code.google.com/p/google-securityre>

- search/ issues / detail?id=675, 2015. (Accessed on 11<sup>th</sup> July 2018)
24. Ormandy. T(2015) Fireeye exploitation: Project zero's vulnerability of the beast. <http://googleprojectzero.blogspot.de/2015/12/fireeye-exploitation-project-zeros.html>, 2015. (accessed on 11<sup>th</sup> July 2018).
  25. T. Ormandy. Analysis and exploitation of an ESET vulnerability. <http://googleprojectzero.blogspot.de/2015/06/analysis-and-exploitation-of-eset.html>, 2015. (Accessed on 11<sup>th</sup> July 2018)
  26. Xue, F.(Online) Nevis Networks inc. : Attackig Antivirus. <http://www.blackhat.com/presentations/bh-europe-08/Feng-Xue/Presentation/bh-eu-08-xue.pdf> [accessed on 13<sup>th</sup> July 2018 ]
  27. Jadidoleslami, J. (2012) Weaknesses, Vulnerabilities and Elusion Strategies against Intrusion Detection Systems. International Journal of Computer Science & Engineering Survey (IJCSSES) Vol.3, No.4, August 2012.
  28. Archana D wankhade, D. A. and Chatur, P. N (2014) Comparison of Firewall and Intrusion Detection System. (IJCSIT) International Journal of Computer Science and Information Technologies, Vol. 5 (1) , 2014, 674-678.
  29. World Economic Forum(2017) Recommendations for Public-Private Partnership against Cybercrime. REF 040117. Geneva.
  30. Hermano, J. H.(2016, online) Cybersecurity Partnerships: A New Era of Public-Private Collaboration. <http://www.lawandsecurity.org/wp-content/uploads/2016/08/Cybersecurity.Partnerships-1.pdf> [accessed on 21<sup>st</sup> July 2018].
  31. Cusack, B. and Liang, J. (2011). Comparing the performance of three digital forensic tools. *Journal of Applied Computing and Information Technology*, Volume 15 Issue 1.
  32. Simon, T, 2012, Discussion on the Challenges and Opportunities of Cloud Forensics, *Multidisciplinary Research and Practice for Information Systems*, Vol. 9, no.1
  33. Almulla, Sameera; Iraqi, Youssef; and Jones, Andrew (2014) "A State-Of-The-Art Review of Cloud Forensics," *Journal of Digital Forensics, Security and Law: Vol. 9 : No. 4 , Article 2*. DOI: <https://doi.org/10.15394/jdfsl.2014.1190>; Available at: <https://commons.erau.edu/jdfsl/vol9/iss4/2>
  34. Carrier, B.(2005) File Systems Forensics Analysis. Addison Wesley professional, Boston.
  35. Rana, N., G Sansanwal, G., Khatter, K and v Singh, S. (online) Taxonomy of Digital Forensics: Investigation Tools and Challenges. <https://arxiv.org/pdf/1709.06529.pdf> [accessed on 30<sup>th</sup> July 2018].
  36. Beebe, N and Clark , J.(2005) Dealing with terabyte data sets in digital investigations. In: Pollit, M. and Shenon, S. (Eds) *Advances in digital forensics: IFIP international conference on digital forensics*. Orlando, Florida Feb 13–16, 2005, Proceedings. Springer: New york, USA.
  37. Avira(Online ) The Application of AI to Cybersecurity |:A n Avira White Paper Link (accessed on 3<sup>rd</sup> August 2018).
  38. Kok, J. N., Boers, E. J. W., Kusters, W. A. , van der Putten, P. and Poel , P. (Online ) *Encyclopedia of Life Support Systems (EOLSS) : ARTIFICIAL INTELLIGENCE – Artificial Intelligence: Definition, Trends, Techniques and Cases*. <http://www.eolss.net/sample-chapters/c15/e6-44.pdf> [accessed on 15<sup>th</sup> August 2018].
  39. Gevarter, W. B (1983) Nasa Technical memorandum 85836 : An Overview of Artificial Intelligence and Robotics Volume I -- Artificial Intelligence
  40. Scherer, M. U. (2016) *Regulating Artificial Intelligence Systems: Risks, Challenges, Competencies, And Strategies*. Harvard Journal of Law & Technology Volume 29, Number 2 Spring 2016.
  41. Hammod, K (2015) *Practical Artificial Intelligence For Dummies*, Narrative Science Edition. John Wiley & Sons, Inc. Hoboken, New Jersey

42. Anwar, M. and Hassan, S. I.(2017) Applying Artificial Intelligence Techniques to Prevent Cyber Assaults. *International Journal of Computational Intelligence Research* ISSN 0973-1873 Volume 13, Number 5 (2017), pp. 883-889
43. Tyugu, E. (2012) Command and Control of Cyber Weapons. *4th International Conference on Cyber Conflict*. Tallinn, Estonia.
44. Padgham, L. and Winikoff, M (2004) Developing Intelligent Agent Systems :A practical guide. John Wiley & Sons Ltd, England.
45. Rhem, A. J. & Associates, Inc (online) The Role of Intelligent Agents in the Information Infrastructure. <http://citeseerx.ist.psu.edu/viewdoc/download?rep=rep1&type=pdf&doi=10.1.1.126.5461> [accessed on 7<sup>th</sup> August 2018]
46. Kukielka, P and Kotulski, Z.(2008) Analysis of Different Architectures of Neural Networks for Application in Intrusion Detection Systems. In *Proceedings of the International Multiconference on Computer Science and Information Technology*. Wisla, Poland. Volume 3.
47. Parveen, J. R (2017) Neural Networks in Cyber Security. *International Research Journal of Computer Science (IRJCS)* Issue 09, Volume 4 .
48. Arockia, P. S, Giri, P. U and Khan, S. K. (2018) Artificial Intelligence Techniques for Cyber Security. *International Journal of Engineering and Technology*, Volume 5, Issue 3.
49. Patil, P. (2016) Artificial Intelligence in Cyber Security. *International Journal of research in Computer Applications and research*. Vol 4, Issue 5.

*This page is intentionally left blank*



Scan to know paper details and  
author's profile

# Improved Oil Recovery vs. Enhanced Oil Recovery

*Prof. Nikolay P. Zapivalov*

*Institute of Petroleum Geology and Geophysics*

## ABSTRACT

Nowadays, the problem of enhanced oil recovery (EOR) and improved oil recovery (IOR) is a key problem in petroleum theory and practice. In world oil-and-gas practice, two different terms are in use: EOR (enhanced oil recovery) meaning intensive, forcible methods; and IOR (improved oil recovery) – advanced and moderate methods.

The enhanced oil recovery methods do not provide a scale effect. There are about 1500 active projects in the world using various EOR technologies, and their annual production build-up is estimated as 100-120 million tons. It is only about 2% of all produced oil in the world, which is equivalent to the total transporting and other losses.

*Keywords:* NA

*Classification:* J.m

*Language:* English



LJP Copyright ID: 975723

Print ISSN: 2514-863X

Online ISSN: 2514-8648

London Journal of Research in Computer Science and Technology



Volume 19 | Issue 1 | Compilation 1.0

© 2019. Prof. Nikolay P. Zapivalov. This is a research/review paper, distributed under the terms of the Creative Commons Attribution-Noncommercial 4.0 Unported License <http://creativecommons.org/licenses/by-nc/4.0/>), permitting all noncommercial use, distribution, and reproduction in any medium, provided the original work is properly cited.

# Improved Oil Recovery vs. Enhanced Oil Recovery

Prof. Nikolay P. Zapivalov

*Author:* Institute of Petroleum Geology and Geophysics, SB RAS Russia, Novosibirsk, 630090, Koptuyuga av., 3.

## I. INTRODUCTION

Nowadays, the problem of enhanced oil recovery (EOR) and improved oil recovery (IOR) is a key problem in petroleum theory and practice. In world oil-and-gas practice, two different terms are in use: EOR (enhanced oil recovery) meaning intensive, forcible methods; and IOR (improved oil recovery) – advanced and moderate methods.

The enhanced oil recovery methods do not provide a scale effect. There are about 1500 active projects in the world using various EOR technologies, and their annual production build-up is estimated as 100-120 million tons. It is only about 2% of all produced oil in the world, which is equivalent to the total transporting and other losses.

In the USA, the “additional” oil recovery is kept at the level of 30-35 MT/Y and has not exceeded this threshold value since 1986. In 1986, there were 512 active projects and in 2008 there were 184, so there is an obvious tendency of a decrease. The situation in other regions of the world is much the same. In terms of the final oil recovery, at many oilfields the efficiency of EOR is very low or zero.

However at present, development of oil-and-gas resources is usually aimed at immediate commercial return; therefore, all possible methods are used for accelerated intensification of oil and gas extraction, which leads to the destruction of the oil deposit as a living system in the thermodynamic rock-fluid interconnection. In this paper, a principally new scientific-

technological paradigm of exploitation, preservation, and rehabilitation of petroleum resources is described.

The author considers an oil deposit in the earth crust as a self-organizing, living fluid-saturated system capable of restoring its balance. Active works during development of an oilfield produce a strong perturbation in the near-equilibrium system, and substantially deform its natural parameters. In case of a moderate perturbation, the self-organizing system restores its balance; a prolonged or intensive perturbation considerably exceeding the critical threshold will destroy the system.

The only way out is to rehabilitate and revitalize such deposits as a whole or as separate productive zones. This will permit to restore the natural energy parameters of fluid saturated systems and also to provide a balanced proportion of hydrocarbons in fractures and porous matrix. Such individual fluid-dynamic cycles, based on self-organization of natural systems, can essentially increase the oil recovery.

Also, a review is presented of promising modern trends in technologies for sparing and moderate development of oil fields (Improved Oil Recovery instead of Enhanced Oil Recovery) aimed at longevity and high oil recovery.

Among the present-day innovative technologies for exploration and development of oil fields, such trends can be distinguished as geofluid-dynamical, seismic-geophysical, geo-mechanical, and technological; besides, there are some ideas and projects not implemented so far.

## II. GEOFLUID-DYNAMICAL ASPECTS; CRITICAL THRESHOLD OF PERTURBATION

Any accumulation of hydrocarbons (fluid-saturated system) is an unsteady system. Depending on various fluctuations and bifurcations, it can be equilibrium or non-equilibrium. The natural accumulations of hydrocarbons can enlarge or grow smaller, or even fully collapse (disappear) in relatively short geological time periods. In fact, it is a self-organizing system.

It is necessary to distinguish two states of an oil deposit in the earth crust: natural state formed before human intervention, and natural-technogenic state during the process of active exploration and development. The active works during the development of an oilfield produce a strong perturbation in the near-equilibrium system and substantially deform its natural

parameters. In case it is a moderate perturbation, the self-organizing system restores its balance.

It is especially important at the late stages of the oilfield life.

A prolonged or intensive perturbation considerably exceeding the threshold will destroy the system. As a result, the formation pressure drops, production rate falls off, the layer is watered out, and even its mineral composition changes.

The perturbation threshold can be estimated through the draw-down pressure. The author has established that the optimal draw-down pressure (formation pressure, FP – bottom-hole pressure, BHP) must not exceed  $5 \div 8$  MPa ( $FP - BHP \leq 5 \div 8$  MPa). This value is almost universal and applicable for all types of reservoirs and many oilfields. It is apparently illustrated in Fig. 1.

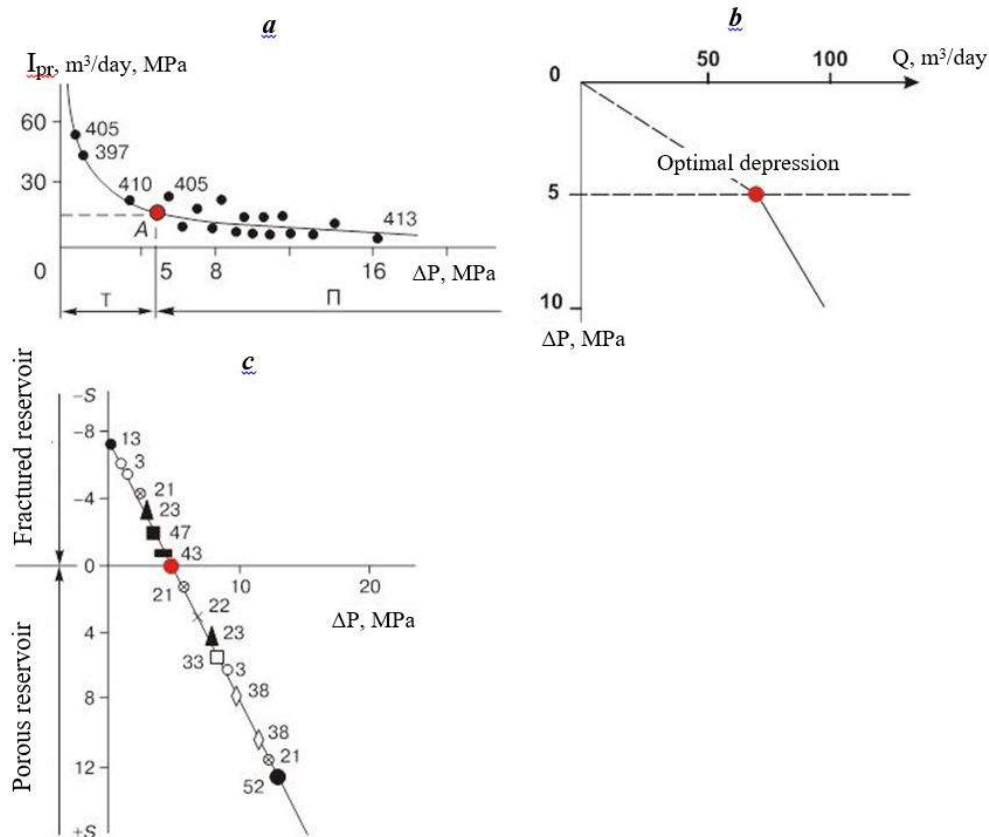

Fig. 1.

a) Indicator diagram and dependence of productivity index ( $I_{pr}$ ) from draw-down pressure in wells. Nizhnevartovsky oil fields, West Siberia.

- b) Indicator diagram for well 43 in Barsu-kovsky oilfield, Belarus.
- c) Description of fluid-dynamic parameters of carbonate reservoirs of porous-fractured type. Correlation between skin-factor and depression (draw-down) at the wells of Beshtentyak oil field, Kirgiz-stan.

The main features of any living system are its energy potential and working capacity. Any oil reservoir is an open fluid-dynamic system with variable exergy and versatile gradients of mass-and-energy transfer. Their threshold values are determined by the boundary parameters of the system at any given moment of time [1].

It is established that the actual reserves of oil and gas can be replenished in the process of oilfield development. It is possible in two cases.

- 1) An active present-day process of hydrocarbon generation is proceeding in the layer. This case was proved in the Mexican bay, Eugene Island oilfield, and also in other regions. An additional feeding (inflow) with newly formed portions of hydrocarbons is possible from both inside and outside the system.
- 2) An individually adjusted moderate development is carried out, with regular periodic rehabilitation works. In this case, a balanced exchange of fluids proceeds between the matrix (block) and filtration channels of the layer. Also, equilibrium is observed between the rock pressure and formation pressure [1, 3].

There are many examples throughout the world demonstrating a renewal of activity in the well after some period of rehabilitation (rest) of the whole oilfield or its separate blocks.

*(N.P. Zapivalov, Novosibirsk, Russia)*

### III. SEISMIC-GEOPHYSICAL METHOD. DYNAMIC-FLUID MODELS (DFM)

Parameters of a fluid-saturated medium of a discrete structure are, by their physical character, functions of elastic modules and of the current stressed state. Therefore, the most appropriate method for estimating the gradient pressure may be based on a complex analysis of the seismic parameters and other geologic and geophysical data [4].

The results of applying DFM-technologies at various world basins showed the possibility to define (prognosticate) the location of the maximum fluid-saturation zones (foci) with a sufficient reliability. The application of DFM-technologies is illustrated in Fig. 2.

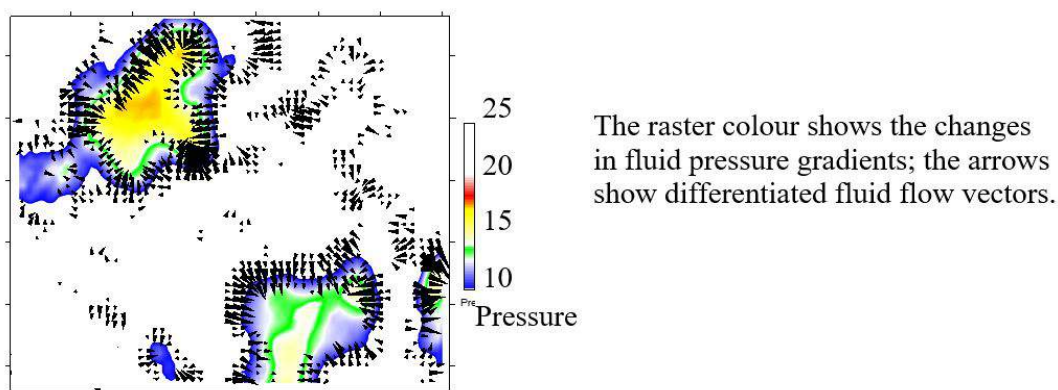

*Fig. 2:* Map of differences of fluid-dynamic parameters [5]

DFM-technology can be effectively applied at all stages of oilfield exploration and development including the process of monitoring; it has already proved successful in various regions. The

technology is aimed at mapping the productive zones (foci) with active fluid cross-flows.

*(V.B. Pisetsky, Yekaterinburg, Russia)*

## IV. GEO-MECHANICAL TECHNOLOGY

### 4.1 Method of directional unloading of the reservoir (rock loosening)

The idea of the rock-loosening method [6, 7] is to create stresses in the well vicinity so as to form multiple new micro- and macro-fractures, by way of non-uniform directional unloading of the reservoir. The unloading is performed through a pressure relief in the well and choosing a special bottom-hole design. This newly generated system of fractures functions as a new network of filtration channels, with a permeability considerably exceeding the initial one.

It should be noted that the rock-loosening method impacts the bottom-hole area in the range up to ten well radii. This accounts for the high effectiveness of the method in development of the producing wells and repair works at the injection wells.

In 1954-1955, S.A. Khristianovich developed a theory and methodology of hydraulic fracturing of oil reservoirs, which up to now remains one of the most effective methods of oil production intensification. In 1990, Khristianovich suggested a totally new approach to the problem of rock deformation, with a gradual decrease of the formation pressure.

Rock sample tests were carried out at the Institute of Problems in Mechanics RAS, at an ITCTS experimental station (Independent Triaxial Compression Testing System). The results demonstrated a remarkable phenomenon concerning the influence of the bottom-hole depression increase on the rock permeability of the well vicinity. Depression of 6 to 9 MPa proved to decrease the rock permeability. It is especially evidently shown in sandstones with high clay content. It presumably results from plastic deformation of clays due to the tangential stresses appearing in the reservoir: they tend to «close» the filtration channels. This corroborates the thesis of geofluid-dynamic critical perturbation threshold  $5 \div 8$  MPa suggested above [8].

This deterioration in the rock permeability of the well vicinity lowers the well productivity. Actually, the effect of a sharp decrease in the well flow-rate due to higher depressions has been frequently observed in practice; there even appeared a special term for it: *collapsing of a reservoir*.

The mechanism of the DUR method (directional unloading of the reservoir) is that of the hydraulic fracturing method, but inverted vice versa.

With the rock-loosening method, development of a well can be conducted simultaneously with rehabilitation of the reservoir permeability in the bottom-hole area. No additional equipment or additional up-and-down operations are required. Thus, both time and expenses needed for the well development essentially decrease while the quality of the works increases.

The rock-loosening method is applicable at any depth of formation. It can produce a considerable economic effect at oilfields where the costs of well drilling and development are high, say at the sea shelf.

It can be supposed to be a most sparing and effective method.

(S.A. Khristianovich, Yu.F. Kovalenko, V.I. Karev, Russia)

### 4.2 Gasgun®: technology of stimulating wells with solid propellants

The necessity to optimise the impact on the bottom-hole area resulted in creating an effective technology with the use of solid propellants – Gasgun® technology. The technology is developed by the research team of *The GasGun Inc.* Co. headed by Dr. R.A. Schmidt [9].

Three various ways of stimulating the reservoir are compared at Fig.3a: explosion, hydraulic fracturing, and the Gasgun® method. The experimental and field tests have shown the Gasgun® method to be the most effective one. Fig.3b shows schematically a typical fracture pattern produced by the Gasgun® technology in

the bottom-hole area of a reservoir. A principal feature of the Gasgun® technology is the use of

solid propellants creating oscillating gaseous jets in the perforated well or even in the open hole.

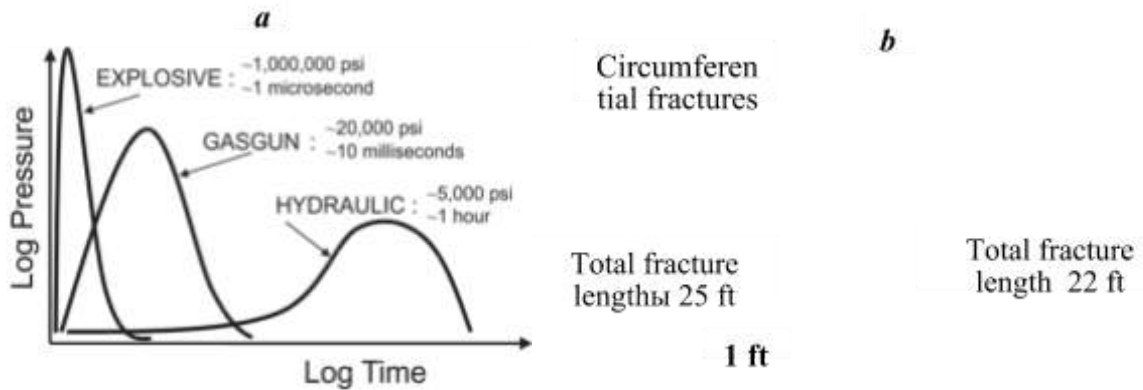

Fig. 3

- Schematic dependence between pressure and time for three various stimulation methods.
- Typical fracture pattern produced by the Gasgun® method in underground experiment.

With the use of solid propellants, large quantities of high-pressure gas can be produced. The burning characteristics of solid propellants can vary in a wide range; through appropriate adjusting of the burning intervals, multiple radiating fractures can be produced in the restricted treatment zone. Their structure will have a number of obvious advantages as compared with the results of the conventional hydraulic fracturing method.

For the last ten years, the Gasgun® method has been already used over 4,000 times in the USA, Canada, Europe, Africa, and Middle East, with the well depth 70 to 3,000 m. Promising results are shown for sandstone, limestone, dolomite, shale, coal, chalk, marlstone, and diatomite.

The developers claim that Gasgun® stimulation has the following advantages as compared with hydraulic fracturing:

- Minimal vertical fracture growth out of the productive zone;
- Multiple circumferential and radiating fractures;
- Selected zones stimulated without the need to set packers off;
- Minimal formation damage from incompatible fluids;
- Homogeneous permeability for injection wells;

- Minimal onsite equipment needed;
- Much lower costs.

This technology undoubtedly must be tested in West Siberia in the terrigenous Mesozoic as well as in the carbonaceous Paleozoic, and surely in other regions of the world as well.

(R.A. Schmidt, *The GasGun Inc, the USA*)

## V. NOVEL IDEAS AND PROJECTS NOT IMPLEMENTED SO FAR

1. Metasomatic dolomitisation: A possibility of applying nano-technologies to form highly-productive reservoirs (artificial metasomatosis).

Oil and gas occur in various natural reservoirs including dolomites, which contain 40% of all the world oil reserves. By changing the architectonic pattern of voids and cavities, dolomitisation can increase the pore volume in compact limestones. This increases not only porosity but also permeability.

It is known that the radius of a calcium ion ( $\text{Ca}^{2+}$ ) is 0.99 Å, or 99 nm, while the size of a magnesium ion ( $\text{Mg}^{2+}$ ) is 0.66 Å, or 66 nm. So, when Calcium is replaced with Magnesium, an additional empty space appears (fractures, caverns etc.). Hence, natural nano-dimensional metasomatic processes facilitate the formation of

high-rate collectors, especially in the Phanerozoic carbonate rocks.

The Maloichskoe oilfield (West Siberia) discovered in 1974 is one of the best-studied oilfields. The main productive horizon is at the depth 2794-2850 m and consists of carbonaceous rocks, namely limestones and dolomites. This oilfield clearly shows the focal character of

dolomitisation, which is eventually the key factor in forming the well productivity. A specific feature of such foci (western and south-western parts of the oilfield, wells 9, 6, 117, 2) is active secondary dolomitisation across the Middle Devonian reef. The areas with high-rate wells apparently prove to coincide with the western facial-tectonic zone (Fig. 5).

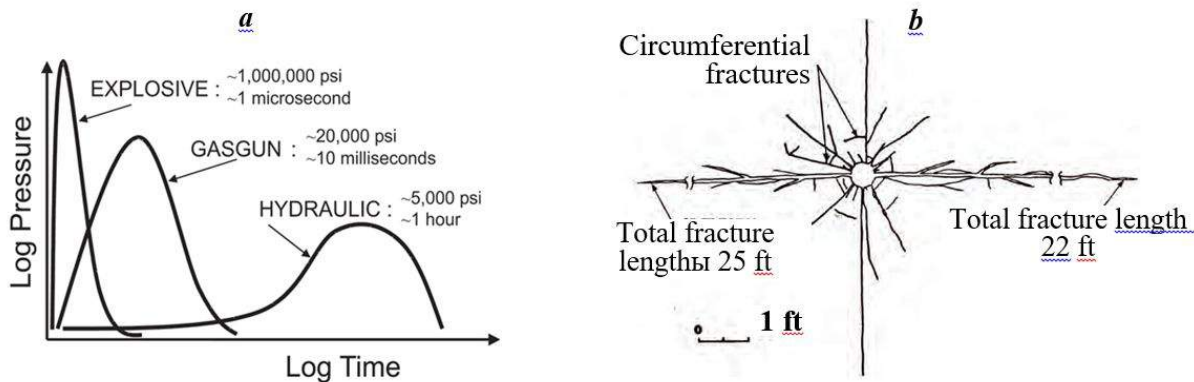

Fig. 5: 3D-seismic survey map of the Maloichskoe oilfield (West Siberia)

It should be noted that metasomatic foci have no definite stratigraphic referencing, and their morphology normally cannot be viewed in terms of folded forms analysis and the superposition law.

It is possible to initiate an accelerated technogenic process of metasomatic dolomitisation so as to create (renew) highly-productive foci at an oilfield. In fact, it will allow managing the process of an oilfield development and increase the oil recovery factor.

For these purposes, we should first determine the composition of the carbonate materials and formation water. The technology of injection of magnesium-containing liquid, or nano-particles of granular magnesium, is unlikely to prove too difficult. As a result, the specific surface of pores and cavities will increase; the fluid cross-flow from the block matrix to the fractures will intensify, and even active formation of new hydrocarbon masses will start. Also, this will stimulate the percolation processes; the well productivity and the actual oil recovery factor will increase. In certain cases, the process of induced and accelerated dolomitisation (metasomatosis)

may be supported with certain wave or thermal stimulation.

In case it is successfully applied, this technology can considerably improve the duration of oilfield development and the total oil recovery factor.

(N.P. Zapivalov, Novosibirsk, Russia)

## 2. Laser-based technologies

These days, the attention is focused on novel breakthrough technologies for studying subsurface resources, geological prospecting, and oil-and-gas production. In a longer prospect, laser-based technologies are supposed to allow almost 100% oil extraction at any oilfield, without environmental pollution [10].

A. Lenetsky, Director of the Research and Production Company «Bereg», claims that the method suggested by the Company is a conceptually new one and has no world analogues. They suggest using laser instead of conventional rock drilling tool. A laser tool does not destroy the rock but rather fuses it; besides, it can pass at an angle, and therefore penetrate into hard-to-reach places. The technology will make it possible to restore old oilfields from which oil

cannot be extracted any more through conventional methods.

In 2012 an American start-up company, *Foro Energy*, also announced that they have developed a technology of laser application in oil production. Their method involves rapidly cracking the surface of hard rocks with a high-energy laser. *Foro Energy* representatives assert that during the test run they managed to send a laser beam of 20 kW through a fibre-optical channel for a distance of 1.5 km. With the *Foro* technology, the intensive laser strike destructs the hard rock in such a way that no further difficulties arise afterwards when a mechanical drilling tool is used. This method can 10 times improve drilling effectiveness. Industrial tests of the technology will take place as soon as in 2014.

*Saudi Aramco* Company reports [11] that their Advanced Research Center has developed a new perforation method using laser technology. This method is supposed to make Saudi Aramco the first to introduce in-situ laser perforation to the petroleum industry.

A direct application of laser perforation will facilitate hydraulic fracturing in open-hole horizontal wells (oriented fracturing), which can greatly enhance the wells' productivity. This technology may show significant advantages as compared with conventional perforation technologies, because it does not involve compaction in the rock.

Specialists of *Saudi Aramco* are sure that the in-situ tests of laser perforation in the well will make a ground for further research in petroleum engineering, including laser drilling.

*(Foro Energy, USA; Saudi Aramco, Saudi Arabia)*

## VI. CONCLUSIONS

1. A principally new scientific-technological paradigm is suggested for developing, saving, and replenishing oil-and-gas resources, with

the account of the critical stability threshold of the system in order to provide for the fluid-dynamic balance. This approach will make it possible to save for long the active oil resources; they can be replenished at the expense of newly formed hydrocarbon masses and soft *sparing* methods of improving oil recovery without destroying the composition, structure, and properties of the fluid-dynamic productive strata.

2. For successful prognosis, effective prospecting and long-term development of oil fields, it is necessary to take account of the latest geo-dynamics of the Earth crust including its behavior in the gradient terms. For these purposes, satellite survey and mapping should be used in various modifications as well as other monitoring technologies.
3. Optimisation of the sparing methods and techniques should be adjusted depending on the individual features of the object.

## REFERENCES

1. N.P. Zapivalov, I.P. Popov Попов. Fluid-dynamic models of oil-and-gas deposits. – Novosibirsk: Geo, 2003. – 198 p. (*in Russian*)
2. A.N. Reznikov. Geosynergetics of oil and gas. – Rostov-on-Don: Publishing house «ЦББП» («Centres of valeology of Russian higher educational establishments»), 2008. (*in Russian*)
3. N.P. Zapivalov, V.I. Lobov. Geofluid-dynamic methods in managing the stressed-deformed state of oil-saturated reservoirs and well productivity. – Geodynamics and Stress State of the Earth's Bowels: Proceedings of International Conference, Institute of Mining Engineering, Novosibirsk, Oct. 6-9, 2003. – Pp. 447-454. (*in Russian*)
4. V.B. Pisetski. Prognosis of fluid-dynamic parameters of a basin based on seismic data. – Yekaterinburg: Ural State Mining University, 2011. (*in Russian*)
5. Zapivalov N. P., Pisetski V. B. New geo-fluid dynamics method for mapping active fluids in

- oil-and-gas saturated strata // DEW: Drilling and Exploration World. – India. – August 2012. – Vol. 21, No 10. – P. 55-60.
6. S.A. Khristianovich, Yu.F. Kovalenko, Yu.V. Kulinich, V.I. Karev. Improvement of productivity of oil wells using the geo-loosening method // Oil & Gas EURASIA. – 2000. – № 2. – P. 90-94.
  7. V.I. Karev, Y.F. Kovalenko. Stress condition control as a method for a perfect well drilling // Oil & Gas EURASIA. – November 2012. – №11. – P. 16-19. (*in Russian*)
  8. N.P. Zapivalov. Dynamics of oilfield life // Bulletin of Tomsk Polytechnic University. – Tomsk: 2012. – V. 321. – No. 1. – P. 206–211. (*in Russian*)
  9. Schmidt R. A. Fracturing with solid propellants offers advantages over traditional stimulation // DEW: Drilling and Exploration World. – India. – October 2009. – P. 47-51.
  10. «Kapital» of December 11, 2013. <http://kapital.kz/economic/24434/v-rossii-nauchilis-dobyvat-neft-s-pomocshyu-lazera.html> (*in Russian*)
  11. <http://theenergyinfo.com/ServiceDetails.aspx?ID=60> (Information Agency *theenergyinfo.com*)



Scan to know paper details and  
author's profile

# Animation and Games Computer Design to Build Awareness of Energy Conservation

*Chavipa Phongthanachote, Ratthasak Phommas & Tika Bunnang*

*Institute of Petroleum Geology and Geophysics*

## ABSTRACT

This research is to design of animation and games computer to build awareness energy conservation tools, these are one of the ways that contribute to the conservation of energy because the main reason for the problems today is that people are not sufficiently aware of the need to conserve energy. Therefore, the solution to the sustainable energy question lies in educating people so that they will become much more aware of energy conservation issues. The promotion of energy conservation would seek to change people's behavior the age of 7-12 years old; the process of education should be used to teach people about the importance of sustainability in energy, hereby developing eco-friendly human behavior.

*Keywords:* energy conservation; awareness; repeat; animation; games computer.

*Classification:* H.5.2

*Language:* English



LJP Copyright ID: 975724  
Print ISSN: 2514-863X  
Online ISSN: 2514-8648

London Journal of Research in Computer Science and Technology

Volume 19 | Issue 1 | Compilation 1.0



# Animation and Games Computer Design to Build Awareness of Energy Conservation

Chavipa Phongthanachote<sup>α</sup>, Ratthasak Phommas<sup>σ</sup> & Tika Bunnang<sup>ρ</sup>

## ABSTRACT

*This research is to design of animation and games computer to build awareness energy conservation tools, these are one of the ways that contribute to the conservation of energy because the main reason for the problems today is that people are not sufficiently aware of the need to conserve energy. Therefore, the solution to the sustainable energy question lies in educating people so that they will become much more aware of energy conservation issues. The promotion of energy conservation would seek to change people's behavior the age of 7-12 years old; the process of education should be used to teach people about the importance of sustainability in energy, hereby developing eco-friendly human behavior.*

**Keywords:** energy conservation; awareness; repeat; animation; games computer.

**Author α σ:** Rattanakosin College for Sustainable Energy and Environment (RCSEE), Rajamangala University of Technology Rattanakosin, 96 m 3 Puthamonthon Sai 5, Salaya, Puthamonthon, Nakhon Pathom, 73170, Thailand.

**Author ρ:** Integrated Solution 98 Co., Ltd. 998 /27 On-Nuch 30-32 Sukhumvit 77 Rd, Suanluang, Bangkok, 10230.

## I. INTRODUCTION

Education is the best way to build awareness, so students, their families, and their teachers, must all be made aware of the need to consume energy in a sustainable manner. Training in sustainable energy use and the economic use of energy must begin from the elementary educational grades, when children first begin their compulsory education. When good habits are instilled in

young children, it is very difficult to change these habits at a later age, and this is why it is so important to provide energy education at an early age, to build long-lasting patterns of responsible behavior. Given that the conservation of energy is such a vital topic, it is essential that education in saving energy is provided at every grade level, especially in Europe where the high demand for energy makes conservation critical. The review of the literature showed that there have been many projects which have focused on the efficient use of energy and schemes to save energy (Mumma *et al.*, 1966; Rowland, 1980; Sarvis, 1980; Wenig, 1981; Theiss, 1982; Crellinsen, 1983; Nicholson, 1996; Newson, 1997; Kirchhoff, 2001; Hjeresen *et al.*, 2002; Papadouris, Constantinou & Kyratsi, 2008).

Awareness means an expression of feeling, opinion, and recognition, such as the condition in which a person understands and assesses situations based on their own experience by referring to a period of time, an event, or an experience from the environment as the factors that lead people towards awareness (Turner, 2008). According to the meaning of awareness as above, awareness refers to feelings in the mind, realizing the responsibility for the problem by evaluation and realizing the importance of their own actions which influence the situation. In this regard, awareness has degrees of relativity, since one can be partially aware, subconsciously aware, or wholly unaware of a situation or problem. Furthermore, one's awareness might be based on internal feelings, or on external events which are understood via the senses.

## II. MEASUREMENT OF ENERGY AWARENESS

The concept of awareness measurement requires behavior to be measured in such a manner that can show the cognition of the students with regard to the existence of the phenomenon or some entity. Awareness is strongly related to intelligence. An awareness of something or someone is a form of knowing that a thing or a person exists, although it is a superficial recognition (Choong Weng Wai, 2009). In

addition, Krathwohl also said of the extent of awareness that it is important to note that the range of awareness appears sequentially from the end of the superficial or cursory awareness to profound gratitude and deliberation. In the context of the teaching of art, an example of cursory awareness is the recognition by realization that there is a painting which has never been realized like that before. Accordingly, this paper follows this conceptual model as follows figure 1:

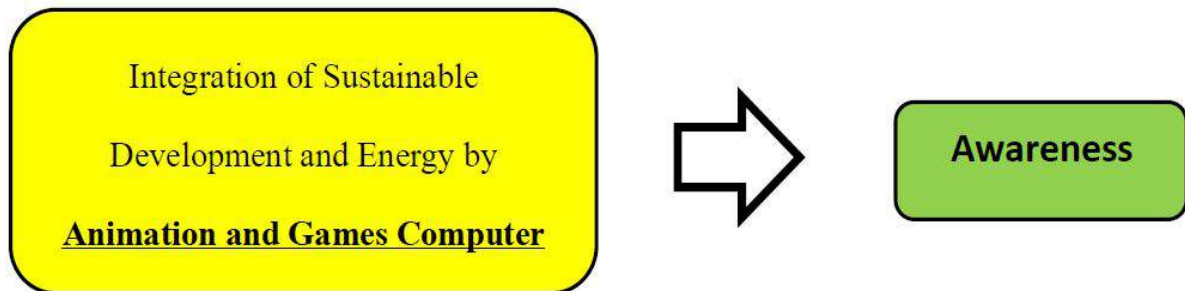

Figure 1: Conceptual model for curriculum development for eco-friendly human behavior

## III. KNOWLEDGE BASED STRUCTURE OF RESEARCH AND RESULT

Energy conservation and sustainable behavior and awareness can be increased through an awareness building approach regarding energy saving which should be taught to children from an early age at a time when they still have continuous ongoing development in all skill areas. In particular, in children aged between 7-12 years, their social development will change increasingly from self-centered to group-centered behavior. Accordingly, the child will build a systematic ability to use logical categories to conceptualize their current environment and thrive within it. Moreover, children and youth will be important role models for the nation for energy conservation in the future. Therefore, an important target group of education for energy conservation should be the group of young people who are currently studying in school, especially those in the elementary level because this education level is the basic compulsory education for all students. By Integrated Curriculum to increase Awareness of Energy Conservation for Primary Schools as the researcher designed figure 2.



Figure 2: Animation and games computer design for sustainable energy conservation

The education system assesses students on their knowledge of a balanced curriculum and on their ability to link concepts across subject areas and to apply the skills learned. Standardized tests offer one means of measuring students' attainment levels. In Japan, the elementary grades run from age 6 to 11, with junior high school from 12 to 14. These nine years comprise the compulsory education in the country, which has a National Curriculum Standards first published in 1947, and modified every ten years thereafter to ensure the subject matter is up to date. The Curriculum Council is responsible for the revisions, under the office of the Minister of Education, Science, Sports and Culture. The National Curriculum must be taught in all schools, and have the basic aim of ensuring that all children receive a balanced education which provides them with the skills required to succeed in a changing society. Researcher have designed Intergrated Curriculum to increase awareness of Energy Conservation for Primary Schools are Animations and Games Computer. As following in Table 1 and 2:

The study of comparison of energy efficiency before and after use Integrated Curriculum to increase Awareness of Energy Conservation of students with lower than 70%. Reseacher considering only the students with the pre-test

results. Less than 70% were found in the level 1, students with pre-test scores lower than 70% or 37.53%. The grade 1 students accounted for 35.38%, grade 2 students accounted for 47.76% and grade 3 students accounted for 29.79%

Less than 70% were found in the level 2, students with pre-test scores lower than 70% or 20.56%. The grade 4 students accounted for 20.59%, grade 5 students accounted for 17.36% and grade 6 students accounted for 23.36% respectively. As show table 1:

*Table 1:* Number and Percentage Students with lower than 70%

Level	Class	n	Score lower than 70%	
			Frequency	Percent
Level 1	Grade 1	130	46	35.38
	Grade 2	134	64	47.76
	Grade 3	141	42	29.79
	Over all	405	152	37.53
Level 2	Grade 4	102	21	20.59
	Grade 5	121	21	17.36
	Grade 6	137	32	23.36
	Over all	360	74	20.56

For students with lower than 70% results in the level 1 and level 2, the results can be compared. Pre-test and post-test by Integrated Curriculum to increase Awareness of Energy Conservation were found every student in every level and every grade. There was a statistically significant difference in the energy saving after school at the .01 level. As following in Table 2:

*Table 2:* Comparison of energy efficiency before and after use Integrated Curriculum to increase Awareness of Energy Conservation of students with lower than 70%

Level	Class	n	Score	Mean	SD	T	p
Level 1	Grade 1	46	Post test	29.652	0.526	29.708**	0.000
			Pre test	15.935	2.894		
	Grade 2	64	Post test	29.375	1.507	37.444**	0.000
			Pre test	17.656	1.845		
	Grade 3	42	Post test	29.262	1.191	21.346**	0.000
			Pre test	17.357	3.252		
	All Level 1	152	Post test	29.428	1.199	48.543**	0.000
			Pre test	17.053	2.711		
Level 2	Grade 4	21	Post test	141.238	12.625	17.071**	0.000
			Pre test	99.143	2.744		
	Grade 5	21	Post test	145.381	8.958	22.094**	0.000
			Pre test	99.619	2.037		
	Grade 6	32	Post test	145.906	9.230	26.856**	0.000
			Pre test	99.750	2.095		
	All Level 2	74	Post test	144.432	10.294	38.056**	0.000
			Pre test	99.541	2.265		

\*\* Statistically Significance at the 0.01

At this research, the researcher considers the percentage difference of energy saving awareness scores. Before and after school by Integrated Curriculum to increase awareness of Energy Conservation. The average and standard deviation are shown in Table 3:

**Table 3:** Average and Standard Deviation of percentage of awareness energy saving points before and after school by Integrated Curriculum to increase Awareness of Energy Conservation

Class	N	Percent Pre test		Percent Post test		t	P
		Mean	SD	Mean	SD		
Grade 1	130	70.563	15.675	98.667	2.140	19.894**	0.000
Grade 2	134	67.811	10.310	98.085	3.929	31.601**	0.000
Grade 3	141	71.631	11.482	98.133	3.070	26.914**	0.000
Grade 4	102	77.287	7.798	96.803	5.399	24.201**	0.000
Grade 5	121	77.906	7.293	96.650	5.601	22.327**	0.000
Grade 6	137	77.391	8.245	97.026	6.144	22.833**	0.000
Over all	765	73.558	11.320	97.605	4.611	53.970**	0.000

\*\* Statistically Significance at the 0.01

Table 3: The researcher were found percentage of Energy awareness score after the study, the statistical significance at 0.01 level, both overall and every year, was show in Figure 3.

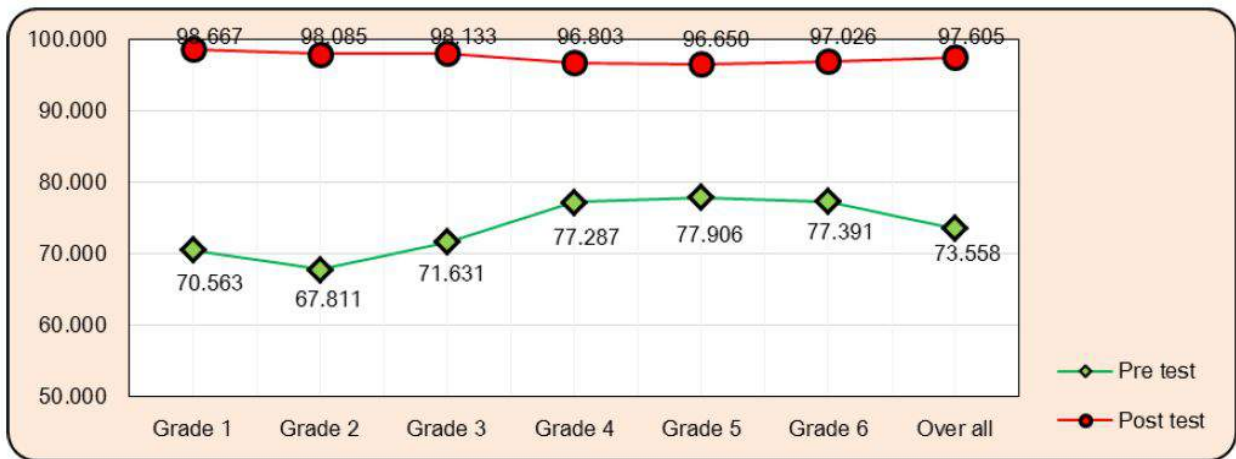

**Figure 3:** Percent Energy awareness rating before and after school

Based on the results of the data analysis by Integrated Curriculum to increase Awareness of Energy Conservation can result in awareness mind saving energy after class change from the previous lesson in level 1 students (Grade 1-3) more than in level 2 students (Grade 4-6) by Integrated Curriculum to increase Awareness of Energy Conservation it is suitable for level 1 students (Grade1-3), Students have a high energy saving score after high school by level 2 students (grade 4-6) there is a difference is slightly in energy awareness scores.

#### IV. CONCLUSION

Studies investigating how children learn during their early years reveal that their initial experiences have a powerful influence upon their later learning and academic success. It is also important that schools take into account the need to meet the requirements of all their students, and in particular not only to focus on academic needs but also on the social, emotional, physical, and psychological needs which enable children to develop as rounded human beings. Schools therefore have a significant responsibility, and as more is understood about child development, the greater that responsibility becomes, requiring schools to invest more time and resources to

deliver high quality education. Furthermore, not all children learn in exactly the same way, and so schools must differentiate in the way lessons are provided in order to meet individual learning needs. For this reason, it is essential to deliver a balanced curriculum so that children's own personal strengths and weaknesses will be

addressed as they develop their skills and knowledge.

Researchers have designed integrated Curriculum to increase Awareness of Energy Conservation "Animation and Games Computer" as following figure 4, 5 and 6.



Figure 4: Pre-test and Post-test by Integrated Curriculum to increase Awareness of Energy Conservation



Figure 5: Experimental Groups Level 1 (Grade 1-3)



Figure 5: Experimental Groups Level 2 (Grade 4-6)

The research study is consistent with review of the literature conducted to inform this study confirms that cooperative learning approaches by “animation and games computer” can lead to greater environmental awareness among elementary school children. By working together, children can support each other in striving to achieve the group objective, but to use this method effectively within the classroom requires a skillful teacher who is adept at organizing group activities which fully engage learners and promote participation from everyone involved. Theories of cooperative learning therefore offer a sound structure to examine the development of sustainable energy awareness in the classroom. This framework allows the key concepts from the field of sustainable energy to be applied through social learning techniques which stem from a solid theoretical foundation in education. This research is consistent with Hilal Aktamis sought to investigate the sustainable energy awareness in high school students along with their energy saving habits in order to examine the influence of socio-demographic factors upon energy-saving knowledge and behavior. In this study, a survey is conducted in order to determine the nature of the status quo. There were 400 participants in the study, comprising students from the 6<sup>th</sup> (162 students), 7<sup>th</sup> (145 students), and 8<sup>th</sup> (93 students) grades. Of these students, 191 were male, and 209 were female; 240 were from urban areas and 160 were from rural areas. The assessment scale used in the study for data collection was the “Energy Saving and Energy Awareness Scale” which comprised 21 items covering 4 factors. The reliability of the survey was tested using Cronbach’s alpha, and the co-efficient was found to be 0.80. One way MANOVA analysis was employed to examine the data, using SPSS version 11.5. It was found that the level of energy awareness among high school students was high.

## REFERENCES

1. Choong W. W. (2009). *The Conceptual Model of Energy Awareness Development Process*. 3rd
2. Crellinsen M (1983). Environmental Awareness and Appropriate Technology, OPCAN, Montreal (Quebec).
3. Cutler J. Cleveland & Christopher Morris (Eds.). (2006) *Dictionary of Energy* Amsterdam: Elsevier.
4. Definition of Sustainability, Benefits-of-Recycling. Retrieved from: <http://www.benefits-of-recycling.com/definitionofsustainability/>
5. Dyar, 1976: 110-111a
6. Energy Policy and Planning Office, Ministry of Energy, Thailand. “Thailand 20-Year Energy Efficiency Development Plan (2011-2030)”. Retrieved on January 11, 2012 from [http://www.eppo.go.th/encon/ee-20yrs/EED\\_P\\_Eng.pdf](http://www.eppo.go.th/encon/ee-20yrs/EED_P_Eng.pdf).
7. Graham Turner (2008). A comparison of the limits to Growth with Thirty years of Reality. ISSN: 1834-5638.
8. Hilal Aktamis (2011) Determining energy saving behavior and energy awareness of secondary school students according to socio-demographic characteristics, *Educational Research and Reviews* Vol. 6(3), pp. 243-250, March 2011 Available online at <http://www.academicjournals.org/ERR> ISSN 1990-3839 ©2011 Academic Journals
9. Hjeresen DL, Kirchhoff MM, Lankey RL (2002). Green Chemistry: Environment, Economics and Competitiveness. *Corporate Environ. Strategy*, 9(3): 259-266.
10. Huyvaert, 1998, p 4.
11. Jessor, R. 1993. ‘Successful adolescent development among youth in high-risk settings’, *American Psychologist*, 48 (2): 117–26. [9] Gardner, G., & Stern, P.C. (2002). *Environmental Problems and Human Behaviour*. Boston: Pearson.
12. Kirchhoff MM (2001). Topics in Green Chemistry, *J. Chem. Educ.*, 78(12): 1577
13. Mumma T, Shaun G, Stone L, Harnish C, Fowle A (1966). *Building Our Children’s Future: An Interdisciplinary Curriculum for Grades K-12, USA, Montana*.
14. National Education Act of B.E.2542 (1999), the Office of the National Education

Commission (ONEC), Prime Minister's Office, Thailand

15. Newson T (1997). "A Science Across Europe" Link Between Schools in London and Berlin. *School Sci. Rev.*, 78(284): 29-31.
16. Nicholson D (1996). Class Projects on the Internet. *Educ. Sci.*, 170: 10-11. Papadouris N, Constantinou CP, Kyratsi T (2008). Students' Use of the Energy Model to Account for Changes in Physical Systems. *J. Res. Sci. Teach.*, 45(4): 444-469.
17. Poortinga W, Steg L, Vlek C (2004). Values, Environmental Concern, and Environmental Behavior A Study into Household Energy Use. *Environ. Behav.* 36(1): 70-93, DOI: 10.1177/0013916503251466.
18. Richmond, 1977:5016A
19. Rowland P (1980). *Influencing Teaching: An Inside View of an Outside Interest Group*, USA, Washington.
20. *Technology Promotion Mag.* June-July 2009, Vol.36 No.205 p.5-7
21. Theiss N (1982). *KEEP-Kentucky's Energy Education Program Activities for the Classroom, K-6*, USA, Kentucky.
22. Thomas, E.J., 2009. *Behavior Modification Procedure a source book.*



Scan to know paper details and  
author's profile

# A Quantitative Technique for Systematic Monitoring of the Treatment Efficiency Psoriasis Lesion

*Tanya Shakir Jarad & Ali J. Dawood*

*University of Anbar*

## ABSTRACT

Psoriasis is a chronic skin disease affecting an estimated 125 million people worldwide. One of the key problems in the management of this condition is the objective measurement of lesion severity over time. Currently, severity is scored by clinicians using visual protocols leading to intra and inter observer variability that makes measurement of treatment efficacy subjective. In this paper, an automatic computer aided image analysis system is proposed that quantitatively assess the changes of erythema and scaling severity of psoriatic lesions in long-term treatment. We develop a method to segment psoriasis lesion in the early stage of diagnosis. In this stage region of interest is very clear that help the k-means clustering to achieve accuracy segmentation. This method has produced a mask which includes the region of interest as white color and background as black color. In the second diagnosis level (scan the region of interest), if the patient case has enhanced, the region of interest will disappear and that will affect the segmentation method and make it a difficult challenge.

*Keywords:* scoring; PASI; the doctor scoring; psoriasis lesion disease; segmentation lesion.

*Classification:* D.4.8

*Language:* English



LJP Copyright ID: 975721  
Print ISSN: 2514-863X  
Online ISSN: 2514-8648

London Journal of Research in Computer Science and Technology

Volume 19 | Issue 1 | Compilation 1.0

© 2019. Tanya Shakir Jarad & Ali J. Dawood. This is a research/review paper, distributed under the terms of the Creative Commons Attribution-Noncommercial 4.0 Unported License (<http://creativecommons.org/licenses/by-nc/4.0/>), permitting all noncommercial use, distribution, and reproduction in any medium, provided the original work is properly cited.



# A Quantitative Technique for Systematic Monitoring of the Treatment Efficiency Psoriasis Lesion

Tanya Shakir Jarad<sup>α</sup> & Ali J. Dawood<sup>σ</sup>

## ABSTRACT

*Psoriasis is a chronic skin disease affecting an estimated 125 million people worldwide. One of the key problems in the management of this condition is the objective measurement of lesion severity over time. Currently, severity is scored by clinicians using visual protocols leading to intra and inter observer variability that makes measurement of treatment efficacy subjective. In this paper, an automatic computer aided image analysis system is proposed that quantitatively assess the changes of erythema and scaling severity of psoriatic lesions in long-term treatment. We develop a method to segment psoriasis lesion in the early stage of diagnosis. In this stage region of interest is very clear that help the k-means clustering to achieve accuracy segmentation. This method has produced a mask which includes the region of interest as white color and background as black color. In the second diagnosis level (scan the region of interest), if the patient case has enhanced, the region of interest will disappear and that will affect the segmentation method and make it a difficult challenge. To avoid this problem we have used the mask of the early stage scans and applied on the second scan image to see the difference between the two regions scan. This process helps us to evaluate severity changes the patient case enhancement on erythema and scaling of lesions. The algorithm proposed in this paper works on 2D digital images by selecting features that can be used to accurately segment erythema and scaling in psoriasis lesions and assess their changes in severity, according to the popular psoriasis area and severity index (PASI).*

*The algorithms are validated by developing objectives that correlate well with changes in severity scores given by dermatologists. To the best of our knowledge, no such computer assisted method for psoriasis severity assessment in a long-term treatment exists. Monitoring severity change psoriasis lesion measures are highly correlated with the dermatologist's decisions than PASI. This and the fact that the obtained measures are continuous indicate the proposed methods are a suitable tool to evaluate the lesion and to track the evolution of dermatological diseases. These systems were evaluated by a number of dermatologists with different experiences.*

**Keywords:** scoring; PASI; the doctor scoring; psoriasis lesion disease; segmentation lesion.

**Author  $\alpha$   $\sigma$ :** Department of Computer Science, College of Computer Science and Information Technology, University of Anbar, Anbar, Iraq.

## I. INTRODUCTION

Psoriasis is a chronic skin disease with no known cure and there are currently an estimated 125 million people worldwide suffering from this disease. A psoriatic lesion manifests as red inflamed skin (erythema) typically surrounding, or partially surrounding, scaly flaky skin (scaling). Pills, balms and radiation treatments are available to control the symptoms of psoriasis, but there is no generally accepted standard treatment for psoriasis. Different dermatologists will treat the same symptoms differently. Further, due to the chronic nature of psoriasis, treatments usually span long time frames. The symptoms may change

with remission, relapse or rebound. To monitor psoriasis, lesions need to be evaluated over a time period [1]. Time-based evaluation will also aid research into psoriasis treatment and clinical practice by facilitating objective treatment comparisons to determine the most effective treatment methods. This paper presents a computer aided image analysis system that to the best of our knowledge is the first to automatically evaluate the changes in severity of erythema and scaling in a long-term psoriasis treatment. Existing methods either manually record the changes or are only applicable to a short-term change assessment. Currently, dermatologists monitor changes of psoriasis by recording psoriasis severity scores over time. A widely used severity scoring system is the PASI score, which requires estimates of the percentage of skin area covered by psoriatic lesions and grades the severity of erythema and scaling. PASI scores for erythema and scaling are currently estimated visually by dermatologists, however, doing this results is unavoidable inter and intra observer variation. The aim of this research is to develop a reliable change assessment system to quantitatively assess the changes of erythema and scaling severities of psoriatic lesions. Computer-aided analysis has been introduced into the area of psoriasis severity diagnosis for a number of decades, but only a very few systems have been implemented that focus on analysing the changes in psoriasis lesions. The only system so far is given in [2], where lesion changes are analysed through lesion image subtraction after registering images of the same lesion. The registration is implemented based on an assumption that in the treatment the psoriatic lesion boundaries do not change and the changes only happen inside the lesion. However, the assumption is only valid for a short term treatment. In long term treatments, psoriatic lesions do not only change within their boundaries, but also the boundary itself changes. Thus change analysis through image registration of the lesions is not suitable for comparisons in chronic treatment [3], [4]. In this paper, we propose a set of features for assessing changes in psoriasis severity for the long term. The features

are based on our previous work on erythema and scaling segmentation of the lesion [5]. For comparison with the algorithms, the ground truth is chosen to be the difference in PASI severity scores and dermatologist's rankings between the two time points for the same lesion.

Psoriasis Area and Severity Index (PASI) is one of the most widespread methods [7] in clinical treatment and research. In [8] *Naldi* reviewed 44 scoring systems used in 171 clinical trials of psoriasis therapies and observed that the PASI scoring was used in about half the trials. PASI scoring was proposed by *Fredricksson and Pettersson in 1978* for use in a single clinical trial, and subsequently became popular. PASI gives a single index that captures the severity in four different body regions: head (occupying 10% of total body surface), upper limbs (20%), trunk (40%), and lower limbs (30%), each of which is weighted based on the proportion to the whole body surface area. In every region, the affected area is graded on a 0-6 scale corresponding to the percentage of coverage. Additionally, the severest psoriasis lesion is picked out in each body part and is rated on a scale of 0-4 by assessing the three symptoms visually: redness, thickness and scaliness. The final score of psoriasis severity is the sum of the scores for the three symptoms, together with the area affected based on the weighting for each region. The equation of the PASI scoring is expressed below:

$$PASI = 0.1(R_h + T_h + S_h)A_h + 0.2(R_u + T_u + S_u)A_u + 0.3(R_t + T_t + S_t)A_t + 0.4(R_l + T_l + S_l)A_l$$

Where  $R_i$ ,  $T_i$ ,  $S_i$  and  $A_i$  are the redness, thickness, scaliness and area scores for different regions of the body, where the subscript  $i \in \{h, u, t, l\}$  indicates the regions head (h), upper limbs (u), trunk (t) and lower limbs (l) respectively. The range of PASI score is from 0 to 72, and this score is discrete, with increments of 0.1 values [9].

Table 1 shows a description of stratification for erythema, scaliness and thickness [10,11,12].

*Table 1:* Description of stratification lesion for erythema, scaliness and thickness

Severity	Scores	Erythema condition	Scaliness condition	Thickness condition
Mild	1	Light red	Partial coverage of lesion with fine scales	Slight elevation
Moderate	2	Red between light red and dark red	Major coverage of lesion with fine to rough scales	Moderate elevation
Severe	3	Dark red	Major coverage of lesion with rough and thick scales	Deep elevation
Very severe	4	Very dark red	Complete coverage of lesion with very rough and very thick scales	Very Deep elevation

## II. RELATED WORK

Many researchers have conducted many studies and researches in medical image segmentation to solve psoriasis disease based on many factors such as according to differences intensity and color. According to *David Delgado* [6], presented combined statistical and image analysis methods to automatically evaluate the severity of scaling and redness in psoriasis lesions. The method realises a hierarchical segmentation to isolate the different structures present in the image normal skin, red area and scales. Results showed that scores are highly correlated with scores made by physicians. *David Delgado Gomez et al* [2], presented a comparative study of the available change detection techniques applied to change visualization and quantification in bi-temporal psoriasis images. The chosen methods are evaluated at a time series of psoriasis images and results are compared with dermatologists' scores.

## III. MATERIALS AND METHODS

### 3.1 Materials

In this research work, we have gathered colored imageries from the psoriasis section of Ramadi teaching Hospital, Ramadi, Anbar under the supervision of a dermatologist. The images were processed in Joint Photographic Expert Group (JPEG) format with color depth of 24 bits per pixel. For this work, a total of the images includes 44 psoriasis colour images that amounted in a total of 22 for the first period and 22 after six months of treatment for the same lesions. Fig 1 shows the diseased skin samples.

The contribution of this paper is to propose model, The assesses the severity changes for long-term of treatment. We develop methods to assess the severity changes without registration of psoriatic lesion images automatically. As explained in the next sections, the previous work on the assessment of changes relies on the registration of lesions in different images. This is only available for short-term treatments, since the boundaries of psoriatic lesions are almost the same in the before/after psoriasis images photographed in short- term treatments. In long-term treatments, not only does the content of the lesion change, but also the boundaries of the same lesion can dramatically change. Therefore, it is hard to conduct lesion registration in this situation. See Fig 1 as an example of images of the same lesion taken different time apart. Physicians are visited by the patients several times to control the evolution of the disease. However, due to the fact that no objective methods to summarize the lesion exist, physicians make scoring and take notes to document the actual condition of the patient. A drawback of this method is the dependency on the individual physician. An experiment over a collection of psoriasis images is conducted to test the performance of the methods. Results show that the obtained scores are highly correlated with scores made by doctors. This and the fact that the obtained measures are continuous indicate that the proposed methods are a suitable tool to evaluate the lesion and to track the evolution of dermatological diseases. Different values are obtained from these areas and they are used to approximate the doctor scoring.



*Fig. 1:* An example of the before-after images taken in a psoriasis treatment. The first row photographed before treatment, the second row photographed after six months of treatment for the same lesion

Since the psoriasis is a chronic disease, it is important to track the condition of the patient to select a proper treatment and to track the condition improvement of the patient. Our proposed model reveal that the severity changes are assessed lesion image registration and without lesion image registration. This section begins with a presentation of these methods, including descriptions of the proposed severity change features. This is followed by an analysis of the consistency between the severity change models and severity scores evaluated by clinicians in the experiments. It is shown that using the proposed method to assess the severity changes is reliable.

### 3.2 Methods

#### 3.2.1 The proposed framework

Observe from Fig 1 that the severity of erythema and scaling is closely related with the composition of the lesion, and consequently that changes in severity are also related to changes in the composition of the lesion. Given a 2D image of a psoriasis lesion, the first step is to segment the elements of the psoriasis lesion, and in particular, to segment erythema and scaling within a lesion. In our work this is done not separately. Segmenting out erythema and scaling allows the calculation of severity of erythema, scaling area and the whole lesion area.

Since the psoriasis is a chronic disease, it is important to track the condition of the patient to select a proper treatment and to track the condition improvement of the patient. Our proposed model reveal that the severity changes are assessed without lesion image registration. This section begins with a presentation of these methods, including descriptions of the proposed severity change features. This is followed by an analysis of the consistency between the severity change models and severity scores evaluated by clinicians in the experiments. It is shown that using the proposed method to assess the severity changes is reliable.

Determining the lesion area is the first step towards the assessment of severity changes. In our previous work [5], an algorithm for segmenting lesion from normal skin is given using a  $L^*a^*b$  color space followed by  $k$ -means clustering scheme with  $k$  value two clusters depending on skin components of the melanin and hemoglobin. *Segmentation Framework:* the chart shows the mechanism the monitoring the treatment for the long term, the segmentation process is applied on the lesion before the treatment, then utilized the segmented process as mask on an image after the treatment. *Monitoring Framework:* the lesion has extracted from the background by using color feature, then features are extracted of the lesion for monitoring severity change the lesion, assess the lesion by two factors: erythema and scaling. Shown in Fig 2.

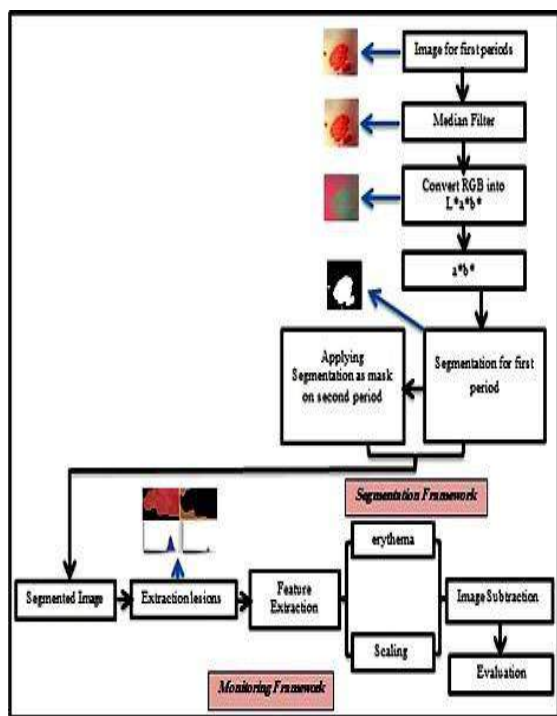

Fig. 2: The proposed system for monitoring the treatment efficiency

### 3.2.2 Erythema and Scaling Segmentation

We proposed *k*-means clustering algorithm for segmenting the lesion depending on color information as shown in [5], monitoring the lesion for long term did not find any sign of the registration the psoriasis lesion or when the color difference between the two objects is small. So, the segmentation with *k*-means method is not accurate because the improvement of lesion is very great, we faced a great challenge as shown in Fig 3.

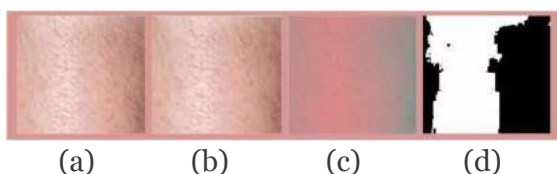

Fig. 3: (a) Original image. (b) Median filter. (c) L\*a\*b\* color space. (d) Shows segmentation stage, difficult segmentation and not accuracy

So we proposed developing methods to solve this problem: applies *k*-means clustering algorithm on the psoriasis image before the treatment, then we take lesion segment and apply it as a mask on the

image psoriasis after six months or more of treatment to discover severity change in the lesion. The development method gives wonderful results for monitoring the efficiency of treatment and to assess the severity changes without registration of psoriatic lesion images. See Fig 4 which shows a mask operation. The value 1 is a location segment lesion on image before treatment. The value 0 is a location of a normal skin.

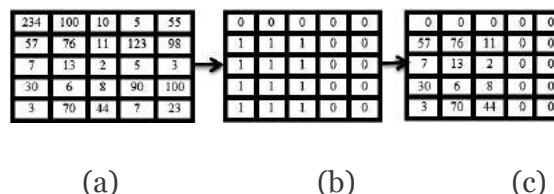

Fig. 4: Shows mask operation. (a): Original image after treatment. (b) Segment lesion before treatment keep segment as a mask. (c) Applying a mask on the image after treatment

The algorithm 1 shows this developing method.

<b>Algorithm 1: Segmentation Without Registration Lesion</b>
<b>Input:</b> Image lesion
<b>psoriasis Output:</b> Image segmentation
<b>Goal:</b> Segmentation without the registration of lesions
<b>Step1:</b> We segmented psoriasis lesion before treatment
<b>Step2:</b> Saving locations lesion as a mask with value 1 and non-interesting object with value 0
<b>Step3:</b> After that we apply a mask on the psoriasis image after treatment
<b>Step4:</b> For each value equals to value1, - We fetch pixels of origin image after treatment.
<b>Step5:</b> Then we return an image with the same area of segment before the treatment
<b>Step6:</b> Finally, we calculate redness and scaling features at two different time points

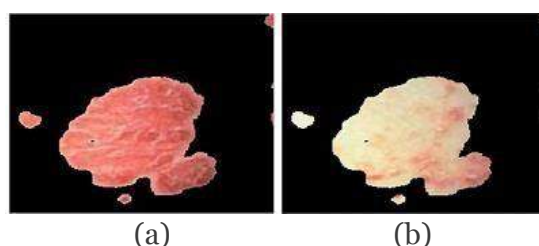

Fig. 6: (a) Shows segment of the lesion psoriasis image before treatment. (b) Shows the application the same segment as a mask on the psoriasis image after 6 months of treatment

### 3.2.3 Severity Change Features of Erythema and Scaling

We use the features of the segmentation algorithm and the segmentation results to quantify the change in lesion severity and specifically on erythema and scaling as shown in [5].

Erythema of psoriasis lesion is related to the degree of skin inflammation and it reflects the severity of redness in psoriasis lesions. Features recognizing and classifying the redness of skin could be considered as good features for psoriasis lesion which can contribute to the whole system of psoriasis image classification. Keeping this in mind, three features can be extracted which indicate the redness of the skin i.e., aggressiveness of red to green, aggressiveness of red to blue, and redness as the ratios of mean values of the R, G and B, where  $\mu_R$ ,  $\mu_G$  and  $\mu_B$  represent the mean values of R, G, and B color component of RGB color space. We proposed using the R-band feature in the RGB color space is considered for the erythema severity scoring. By the color histogram feature of RGB color space, then the mean R  $\mu_R$  of red channel is calculated applying the following function.

$$Erythema = \frac{\sum \text{density red pixels of the lesion}}{\text{No. pixel classified as redness}} \quad (1)$$

The scale feature in lesions represents white (brightness) colors and notices the variations intimate to lesions, thereby the anticipated procedure appropriates the grouping of image bands to be a principal constituent towards independent histogram and convert to grayscale images by means. The threshold employed with uppermost threshold values of histograms, every pixel with values between (240-255) of the density has been estimated, see Fig 7. Subsequently, by calculating the number of pixels classify as scaling, by using the function to calculate ratio scaling of the lesion. The algorithm 2 describes the process. The steps of the algorithm are as follows:

**Algorithm 2: Extracting Scaling of The Lesion**

**Input: Color image**  
**Output: Scales feature**  
**Goal: Calculating scales in the lesion**

**Step1:** Converting the image into 2-D a grayscale image.  
**Step2:** Counting No. Pixel classification as scale (brightness) between 240-255 scale of the density  
**Step3:** Calculate the scale area as calculated by **Gomez et al, in 2007:**

$$Area_{scaling} = \frac{\text{No. pixel classified as scale}}{\text{Area of the lesion}} \quad (2)$$

Fig. 7: Column (a) shows red channel and a histogram. Column (b) shows a grayscale image and histogram. Changes in lesion severity are described by a subtraction between the severity features of a lesion at one time point and the features of the same lesion at another time point. A general severity change function  $D(X)$  is expressed as:

$$\Delta D(E,S) = X_2(E,S) - X_1(E,S) \quad (3)$$

Where  $X_1$  is the severity features at the first time point, and  $X_2$  is the severity features at the second time point, and the change in erythema severity within a lesion can now be defined by the redness severity change feature set, which is related to changes of the relative quantities of redness of histogram for the red channel.  $S$  the change in scales severity within a lesion can now be defined by the scales severity change feature set, which is related to changes of the relative quantities of white pixels in a grayscale image.

#### IV. EXPERIMENTAL VALIDATION

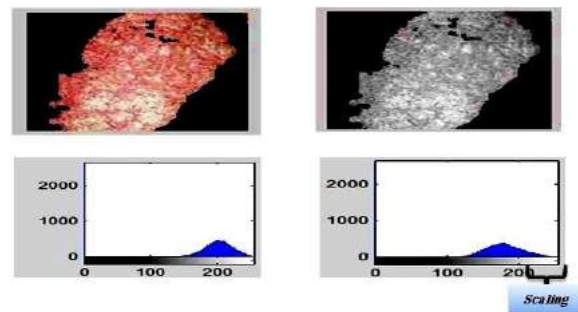
Psoriasis skin images are collected from a number of sources the imaging environment is carefully set to ensure controlled illumination. The set of images was chosen to include various skin types. The images for a specific lesion were collected at two different time points and given PASI scores and dermatologist's rankings by a dermatologist. Only those images that were given identical PASI scores and dermatologist's rankings by the dermatologist for both time points were selected. For comparison with the algorithms, the ground truth is chosen to be the difference in PASI severity scores and dermatologist's rankings between the two time points for each lesion. We note that a straight subtraction of severity scores between two time points may yield a negative value indicating a decrease in severity, or a positive value indicating an increase in severity. The situation is symmetrical for our analysis. In this case, only severity decrease is considered in the experiment. Additionally, when zero is given by subtraction of severity scores, it may imply that the severity change could not be recognized by dermatologists. Table 1 shows the results for 22 images with erythema severity changes and Table 2 shows the results for 22 images with scaling severity changes for the long term.

In Tables 1 and 2 the "PASI Score before" and "PASI Score after" are the severity scores given by a dermatologist at the first time point and the

second time point respectively. The "D. Score " is the severity change scores given by a dermatologist if -1 decrease severity, if +1 increase severity and if 0 refers not changes in severity of psoriasis lesions. It is used by *Gomez et al, in 2007*. The results will match the doctors scores. Different values are obtained from these features and they are used to approximate the doctor scoring.

$$f(x) = \begin{cases} -1, & \text{if } x < 0 \\ 0, & \text{if } 0 \leq x < 0.012 \\ +1, & \text{if } x \geq 0.012 \end{cases} \quad (4)$$

The purpose of this comparison was to assess the involved change of psoriasis lesion before and after different anti-psoriasis treatments using the Computer Image Analysis (CIA) system and human eye for doctors scores and PASI.

In columns 2 and 4 of tables 1 and 2 refer feature extracted (erythema and scaling for long term) by proposing algorithms at the first time point and the second time point respectively. In column 7 of tables 1 and 2 refer to severity change features of the subtraction image process of severity scores. Table 1 shows the experimental results for severity change redness of the lesion.



Fig. 8: Shows segmented as mask process

Table 2: Erythema severity change scores with the severity change features and the before-after treatment for a long time

Index	Severity Redness Lesion before	PASI Score before Redness (0-4)	Severity Redness Lesion after	PASI Score after Redness (0-4)	Change PASI Score	Change severity	D. Score
1	156.1731	2	158.9142	1	-1	2.7411	-1
2	212.9120	3	172.7055	0	-3	-40.2066	-1
3	227.5433	3	0	0	-3	-227.5433	-1
4	225.4975	2	81.3333	1	-1	-144.1642	-1
5	213.9814	2	168.3043	0	-2	-45.6771	-1
6	193.1651	3	170.5469	0	-3	-22.6182	-1
7	203.2937	3	181.7252	0	-3	-21.5684	-1

8	215.0190	3	147.8519	0	-3	-67.1671	-1
9	217.7194	3	127.2400	0	-3	-90.4794	-1
10	204.5251	3	167.3625	1	-2	-37.1627	-1
11	203.5606	3	161.7486	1	-2	-41.8120	-1
12	216.8542	3	185.9413	0	-3	-30.9128	-1
13	183.7717	3	169.3432	0	-3	-14.4285	-1
14	208.3042	2	193.7579	1	-1	-14.5463	-1
15	212.9171	3	192.6316	1	-2	-20.2855	-1
16	194.6578	1	164.0204	1	-0	-30.6374	-1
17	153.4264	3	147.3454	1	-2	-6.0810	-1
18	187.9873	2	182.0964	0	-2	-5.8909	-1
19	195.8928	3	174.6143	0	-3	-21.2785	-1
20	223.1629	2	192.9419	1	-1	-30.2209	-1
21	164.7064	1	154.3671	0	-1	-103393	-1
22	176.2479	1	166.2686	1	-0	-9.9792	-1

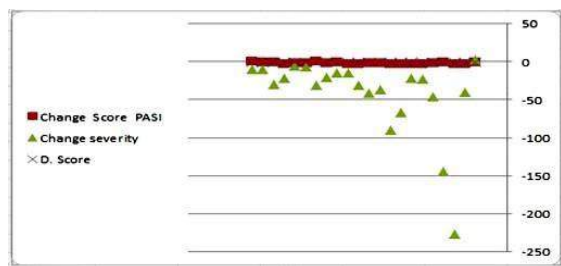

Fig. 9: Distribution of redness severity change features in Table 1 and the severity change Score

means The redness measurement is more accurate for the assessment of small severity changes which PASI is not able to measure them while the results will match the doctors scores exactly, except for the difference index 1. Table 2 shows the experimental results for severity change scaling of the lesion.

The results will match the PASI scores exactly, except for the difference index 16 and 22. This

Table 3: Scales severity change scores with the severity change features and the before-after treatment for a long time

Index	Ratio Scaling Lesion before	PASI Score before Scales (0-4)	Ratio Scaling Lesion after	PASI Score after Scales (0-4)	Change PASI Score	Change ratio	D. Score
1	4.7072e-05	3	4.7072e-05	1	-2	0	-1
2	0.0695	2	4.0683e-05	0	-2	-0.0695	-1
3	1.3016e-04	2	1.3016e-04	0	-2	0	-1
4	7.0502e-05	2	7.0502e-05	0	-2	0	-1
5	0.0904	3	2.0994e-04	1	-2	-0.0902	-1
6	3.8310e-05	2	3.8310e-05	0	-2	0	-1
7	7.5592e-05	2	7.5592e-05	0	-2	0	-1
8	6.1275e-05	3	6.1275e-05	0	-3	0	-1

9	5.8048e-05	2	5.8048e-5	0	-2	0	-1
10	3.6929e-05	3	3.6929e-05	0	-3	0	-1
11	4.8558e-05	2	4.8558e-05	0	-2	0	-1
12	3.8542e-05	2	3.8542e-05	0	-2	0	-1
13	3.9939e-05	3	3.9939e-05	0	-3	0	-1
14	4.0399e-05	2	4.0399e-05	0	-2	-0.0085	-1
15	0.0085	3	5.5797e-05	0	-3	-0.0010	-1
16	0.0011	2	3.4528e-05	1	-2	0	-1
17	5.7127e-05	1	5.7127e-05	0	-1	0	-1
18	8.2142e-05	1	8.2142e-05	0	-1	0	-1
19	9.2764e-05	2	9.2764e-05	0	-2	0	-1
20	7.8771e-05	1	7.8771e-05	0	-1	0	-1
21	7.5131e-05	2	7.5131e-05	0	-2	0	-1
22	5.1096e-05	2	5.1096e-05	1	-1	0	-1

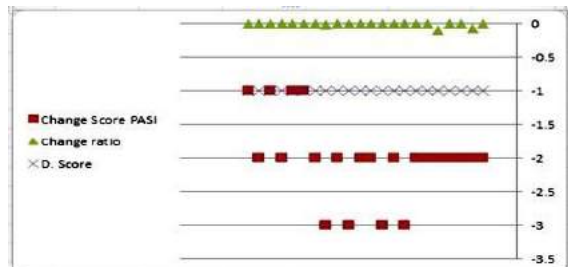

Fig. 10: Distribution of scale severity change features in Table 2 and the severity change score

The results of the subtraction process of extracting features are equal to zero, this didn't mean it do not occur any improvement in the lesion, because the skin didn't come back normal again. Even if the highest improvement in the lesion where the skin becomes more white than other normal skin. So when we calculate the scaling severity change in the long term, the results were negative and zero which means decrease severity. So the results will match the PASI score and the doctors score exactly. When evaluating the monitor system proposed with two ground truth PASI and doctor's score, the results of the system match the doctor's score exactly except for some cases.

Table 4: Shows accuracy of the monitoring severity change system

Features	Long term model
Area	-----
Redness	95.45%
Scaling	100%
Average accuracy of all features	97.72%

## V. CONCLUSIONS

In this paper, a procedure to quantify the changes of erythema severity and scaling severity is presented. The erythema severity change features and the scaling severity change features are developed according to PASI severity scoring instructions. Severity change features determined by the algorithms are strongly correlated with the PASI severity scores given by dermatologists. Moreover, the algorithm shows promise for automatically quantifying severity changes in psoriasis lesions. In the future, we will further

investigate the severity change features, especially the roughness features in scaling, as well as collecting more lesion samples to explore relationships between the severity features resulting and PASI severity scores, and to improve the result of the severity change quantification.

## REFERENCES

1. L. Naldi and D. Gambini, "The clinical spectrum of psoriasis," *Clinics in Dermatology*, vol. 25, no. 6, pp. 510–518, 2007.
2. D. D. Gomez, C. Butakoff, B. Ersbll, and J. M. Carstensen, "Automatic change detection and quantification of dermatological diseases with an application to psoriasis images," *Pattern Recognition Letters*, vol. 28, no. 9, pp. 1012–1018, 2007.
3. J. Lu, J. Manton, E. Kazmierczak, and R. Sinclair, "Erythema detection in digital skin images," in *Image Processing, 2010. 17th IEEE International Conference on*, 2010, pp. 2545–2548.
4. J. Lu, E. Kazmierczak, J. Manton, and R. Sinclair, "Automatic segmentation of scaling in 2D psoriasis skin images," *Medical Imaging, IEEE Transactions on*, vol. 32, no. 4, pp. 719–730, 2013.
5. Jarad, Tanya Shakir, and Ali J. Dawood. "Accurate Segmentation of Psoriasis Diseases Images using K-means Algorithm based on Cielab (L\*a\*B) Color Space." *Journal of Theoretical & Applied Information Technology* 95.17 (2017).
6. Gomez, David Delgado, Bjarne Kjær Ersbøll, and Jens Michael Carstensen. "An image based system to automatically and objectively score the degree of redness and scaling in psoriasis lesions." (2004).
7. Puzenat, E., et al. "What are the best outcome measures for assessing plaque psoriasis severity? A systematic review of the literature." *Journal of the European Academy of Dermatology and Venereology* 24.s2 (2010): 10-16.
8. Naldi, Luigi. "Scoring and monitoring the severity of psoriasis. What is the preferred method? What is the ideal method? Is PASI passé? Facts and controversies." *Clinics in dermatology* 28.1 (2010): 67-72.
9. Louden, B. Asher, et al. "A Simplified Psoriasis Area Severity Index (SPASI) for rating psoriasis severity in clinic patients." *Dermatology online journal* 10.2 (2004).
10. Shrivastava, Vimal K., et al. "First review on psoriasis severity risk stratification: An engineering perspective." *Computers in biology and medicine* 63 (2015): 52-63.
11. Feldman, S. R., and G. G. Krueger. "Psoriasis assessment tools in clinical trials." *Annals of the rheumatic diseases* 64. suppl 2 (2005): ii65-ii68.
12. Fadzil, MH Ahmad, et al. "Area assessment of psoriasis lesions for PASI scoring." *Journal of medical engineering & technology* 33.6 (2009): 426-436.



Scan to know paper details and  
author's profile

# Performance Analysis of Dispersion Compensation System Schemes at 10gb/s Compare RZ & NRZ Pulse Generators with PIN and APD Photo Detectors Device

*Muthana. Y. Aldouri*

*Al-Nisour University College*

## ABSTRACT

In this paper, the dispersion compensating method is done by comparing two systems designed for high data rates 10 Gb/s, and laser source generated from CW laser at 1552nm wavelength. The influence of EDFA power and increase in length of each system of fiber has been studied to evaluate the performance of optical communication systems. The performance characteristics like bit error rate, eye diagrams at the output is studied by simulating different systems. The two system is to comparing pulse generators (RZ & NRZ) and photodiodes types (PIN & APD) in one designed –compensation dispersion system, it is found that the later is superior to the former. Further, it has also been observed that system needs proper matching between the EDFA power and length of the fiber for most favorable show, besides the maximum fiber length in this system reach to 280 Km long.

**Keywords:** RZ & NRZ pulse generators, PIN & APD photo detectors, simulation software, EDFA amplifiers, CW laser, loop control.

**Classification:** B.7.m

**Language:** English



LJP Copyright ID: 975721  
Print ISSN: 2514-863X  
Online ISSN: 2514-8648

London Journal of Research in Computer Science and Technology

Volume 19 | Issue 1 | Compilation 1.0

© 2019. Muthana. Y. Aldouri. This is a research/review paper, distributed under the terms of the Creative Commons Attribution-Noncommercial 4.0 Unported License <http://creativecommons.org/licenses/by-nc/4.0/>), permitting all noncommercial use, distribution, and reproduction in any medium, provided the original work is properly cited.



# Performance Analysis of Dispersion Compensation System Schemes at 10gb/s Compare RZ & NRZ Pulse Generators with PIN and APD Photo Detectors Device

Muthana. Y. Aldouri

## ABSTRACT

*In this paper, the dispersion compensating method is done by comparing two systems designed for high data rates 10 Gb/s, and laser source generated from CW laser at 1552nm wavelength. The influence of EDFA power and increase in length of each system of fiber has been studied to evaluate the performance of optical communication systems. The performance characteristics like bit error rate, eye diagrams at the output is studied by simulating different systems. The two system is to comparing pulse generators (RZ & NRZ) and photodiodes types (PIN & APD) in one designed –compensation dispersion system, it is found that the later is superior to the former. Further, it has also been observed that system needs proper matching between the EDFA power and length of the fiber for most favorable show, besides the maximum fiber length in this system reach to 280 Km long.*

**Keywords:** RZ & NRZ pulse generators, PIN & APD photo detectors, simulation software, EDFA amplifiers, CW laser, loop control.

**Author:** Al-Nisour University College/Department of Computer Technical Engineering/Baghdad-Iraq.

## I. INTRODUCTION

Recently, there has been great interest in using single mode fibers [1] for high-bit-rate transmission in low loss transmission windows but dispersion is an important impairment that

degrades overall system performance of an optical communication system. At high-bit-rate, the dispersion-induced broadening of short pulses propagating in the fiber causes crosstalk between the adjacent time slots, leading to errors when the communication distance increases beyond the dispersion length of the fiber [2]. as the channel communication system rate was increased, the tolerance for dispersion is strongly reduced. The advent of erbium-doped amplifiers (EDFAs) operating in the 1.55  $\mu\text{m}$  region has increased the link distance as limited by fiber loss in optical communication systems. However, these amplifiers induce nonlinear effects, which not only limit the bit rate but also the propagation distance in an optical fiber link.

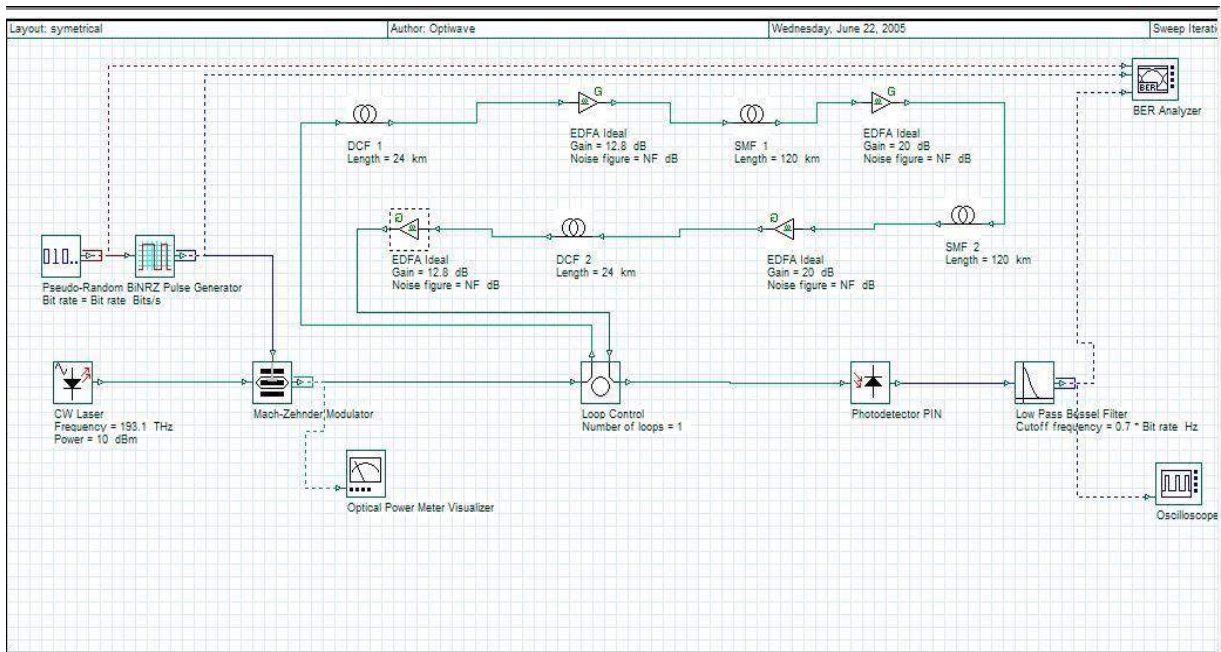

Figure 1: Simulation setup block diagram system design

Dispersion management in single mode fiber links can be accomplished in many ways, though the most widely used approach employs lengths of transport fiber of opposite dispersion characteristics to the principal fiber in the link, usually standard single mode fiber (SSMF). Typically a 10 to 20km length of dispersion compensating fiber (DCF) is placed before the regenerators inducing negative dispersion to compensate for the positive dispersion accumulated over the 60 to 80km length of the SMF. Although the total dispersion over the entire SMF-DCF span can be minimal, net dispersion at any point along the span is non-zero, which keeps the nonlinear mixing effects at minimum levels. The following figure shows performance for an uncompensated (i.e., SMF span = 100km, and DCF span = 0km) link. The power map rises with the link length because the amplifier over-compensates for the attenuation at each span. Since there is no dispersion scheme employed, the accumulated dispersion for each wavelength produces a closed eye at the receiver even if the link is not power-limited.

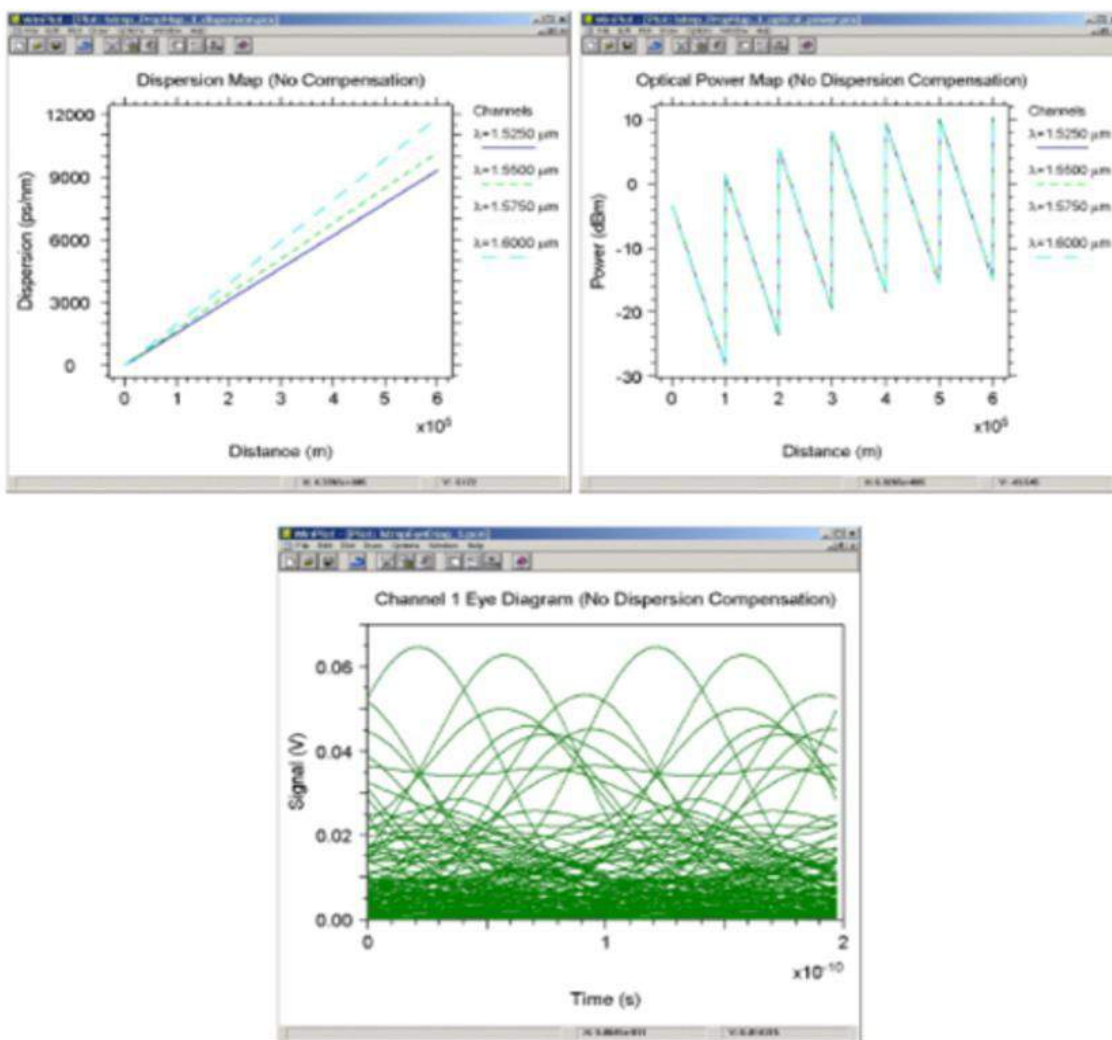

Figure 2: Figure shows performance for an uncompensated

The use of dispersion compensated fiber is an important method for dispersion compensation and to upgrade the already installed links of single mode fiber [3].

Dispersion compensated fibers are specially designed fibers with negative dispersion. The high value of negative dispersion is used to compensate for positive dispersion over large lengths of ordinary fiber. The total negative dispersion compensates for the total positive dispersion.

In the other hand for long length there is a difference between RZ and NRZ pulse generators as the system designed for each of them as shown below.

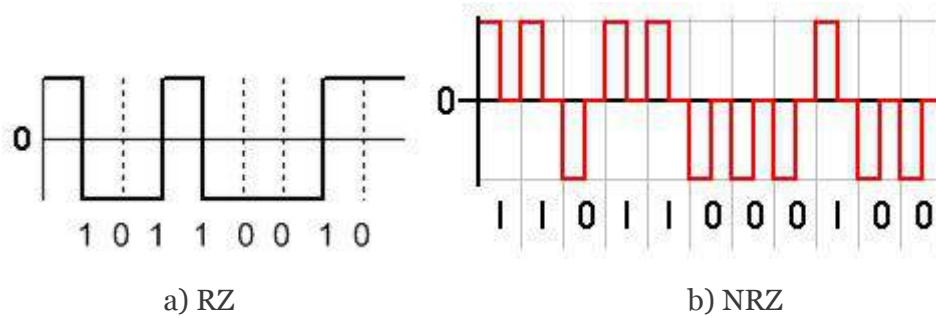

Figure 3: [a] NRZ, [ b] RZ) data signal format

Two formats are included in this modulation group: Non-return-to-zero (NRZ) and Return-to-zero (RZ). NRZ is the oldest and simplest modulation format and is obtained by switching a laser source between ON or OFF. RZ describes a line code used in telecommunications signals in which the sign drops to zero between each pulse. This takes place even if a number of consecutive “0” or “1” occurs in the signal. The signal is self-clocking. This revenue that a separate clock does not need to be sent alongside the signal, but suffers from using twice the bandwidth to accomplish the same data-rate as compared to non-return-to-zero format. Although return-to-zero (RZ) hold a provision for synchronization, it motionless has a DC component resulting in ‘baseline wander’ during long strings of (0) or (1) bits, just like the line code non-return-to-zero. The RZ and NRZ data signals formats are showing in figure 1.a&b respectively [1].

Besides, for most common semiconductor photo detector is the PIN photodiode, which consists of an intrinsic semiconductor sandwiched between *p*-doped regions. While PIN photodiode is normally subjected to a reverse bias. In an APD the absorption of an incident photon first produces an *e-h* pair just like in a PIN. The large electric field in the depletion region causes the charges to accelerate rapidly [4].

So in order to calculate the dispersion of this system mathematically by taking the 1552 nm wave length bandwidth and for maximum fiber length distance as working in the system we designed in this paper which totally equal to 180

Km then the dispersion of 1552.52 nm wave length the result is as follows[5]:

The general formula for dispersion compensating is

$$D\lambda = S_o / 4(\lambda - \lambda_o^4 / \lambda^3) \quad (1)$$

As the system we designed the value of dispersion can be calculated as

$$D\lambda = 0.092/4 (1552.52 - 13114 / 1552.52^3) \quad (2)$$

$$\text{then } D\lambda = 17.55\text{ps/nm.} \quad (3)$$

For 280 Km transmission distance as in this system .the dispersion is as follows:

$$D = (17.55\text{ps/nm}) / 280\text{Km} = 0.06\text{dBm} \quad (4)$$

From this result we can find that the whole dispersion is not exceeding the standard value of 1.5 dBm. Which appears very interesting in transmission link[6]?

1. Simulation:

Referring to figure 1.

- 1- Maximum power signal is 6 dBm
2. Wavelength at 1552 nm
2. Noise power equal to (-100 dBm)
3. Lower frequency limited = 1620.5nm
4. upper frequency limited = 1498.96nm
5. To ensure the linearity of the system, the CW laser is properly biased and the peak –to-peak voltage of the input signal cannot exceed the specified values.

The simulation has been carried out by using opt system software version 7. In this occupation we used CW laser 1552 nm, as a lighting emission source to transmit data over 288 km length

through one loop control and EDFA gain 20 dB. The systems build as figure 7. This figure shows the system design of dispersion compensation

FBG by simulation software version 7. we can use this system to find the effect and calculation of dispersion compensation in fiber optics.

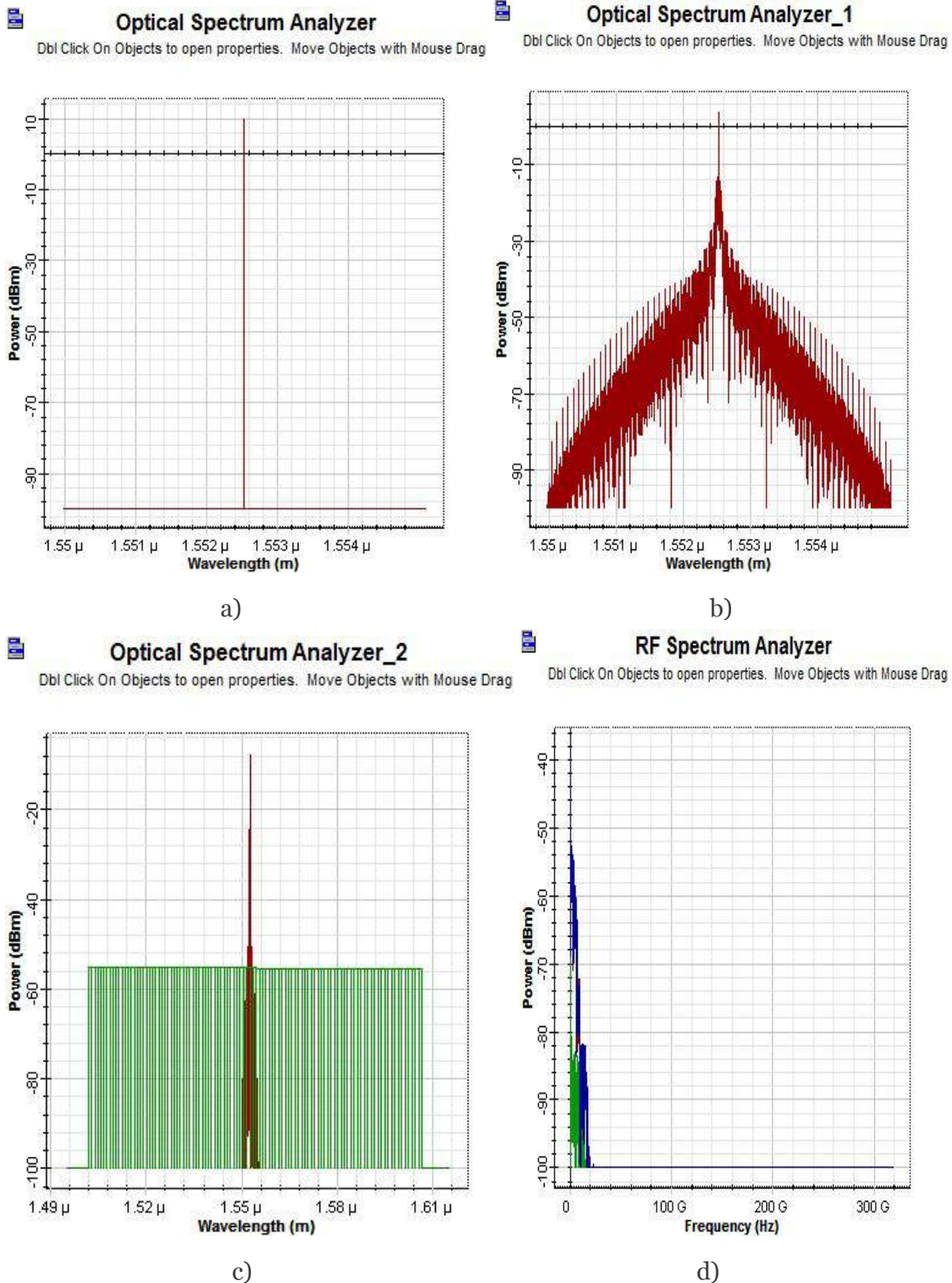
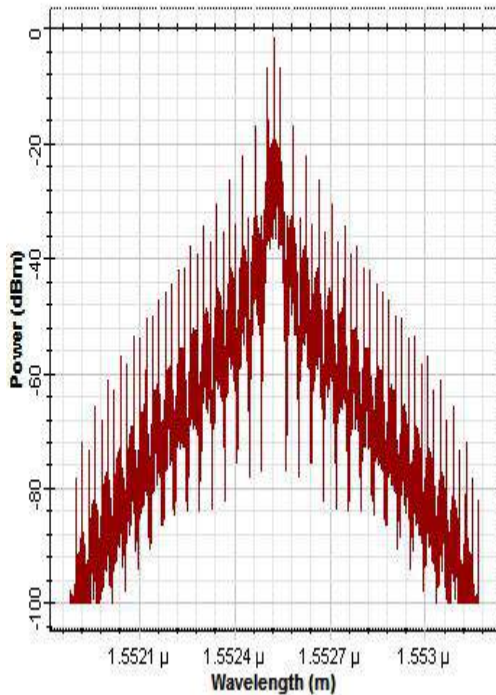

Figure 5: Optical RF spectrum analysis at different values of power

- a) Spectrum signal of input power at 15.5dBm from CW laser
- b) NRZ, PIN input spectrum signal at the transmission link, maximum amplitude 8.9dBm
- c) NRZ, PIN output spectrum signal at the output of transmission link, maximum amplitude -3dBm.
- d) RF spectrum at -35 dBm at the output of the system

**Optical Spectrum Analyzer**  
 Dbl Click On Objects to open properties. Move Objects with Mouse Drag



a)

**Optical Spectrum Analyzer\_2**  
 Dbl Click On Objects to open properties. Move Objects with Mouse Drag

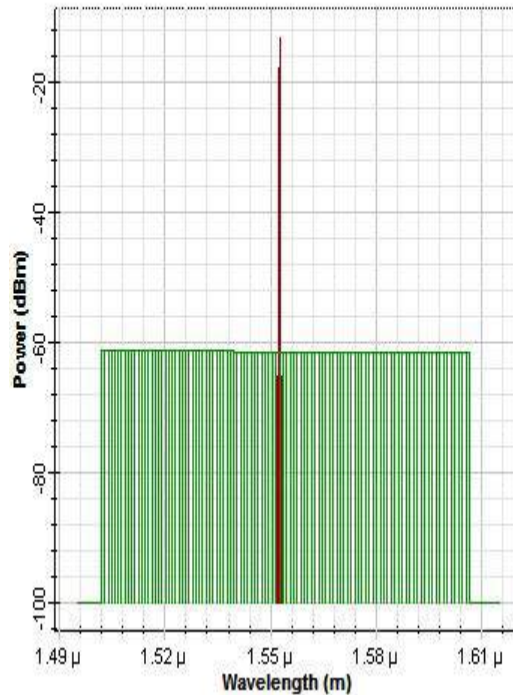

b)

Figure 6: Spectrum signal measuring amplitude illustrated as:

- a) RZ, APD at the input of the transmission line maximum amplitude 3.4 dBm
- b) RZ, APD at the output of the transmission line maximum amplitude -8.7 dB

Referring to the figure 7, is the comparing between most two types of photodiodes at fixed data rate equal to 10Gb/s, with input power varying from 1 to 10 dBm ,the result illustrated that APD is high resolution effect more than that at using PIN as appeared in the values of BER which is equal to

At 1dBm	PIN	APD
BER	$2.9e^{-4}$	$5.9e^{-4}$
At 10 dBm	$2.3 e^{-3}$	$4.6 e^{-3}$

Depending on the characteristics of the two types of photodiodes.

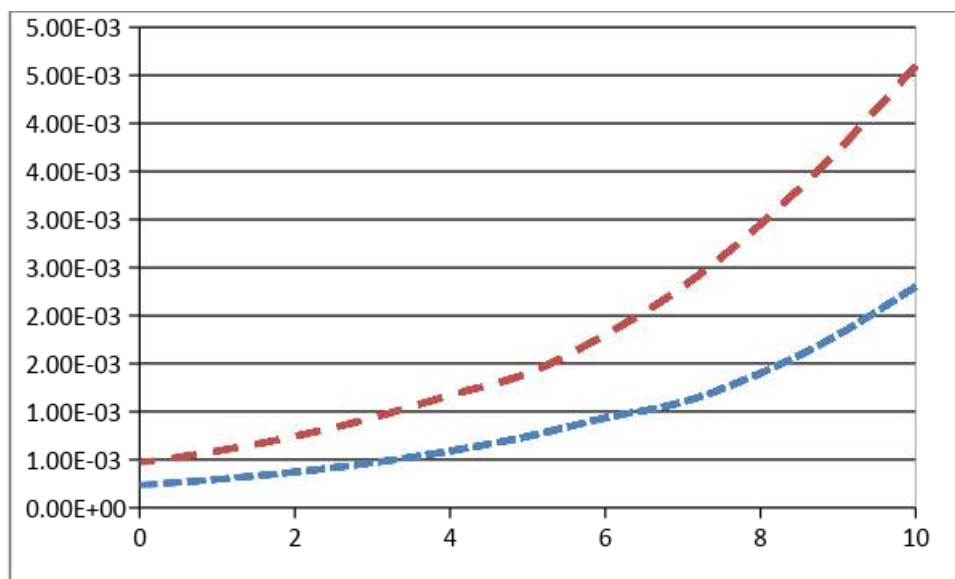

Fig7: Relation between powers input (dBm) and power output with BER when using two types of photo detectors PIN and APD.

The same description for figure 8, with respect to two types of RZ and NRZ

	RZ	NRZ
At 1dBm	$1.1e^{-19}$	$1.1 e^{-12}$
At 10 dBm	$1.5e^{-121}$	$2.2 e^{-114}$

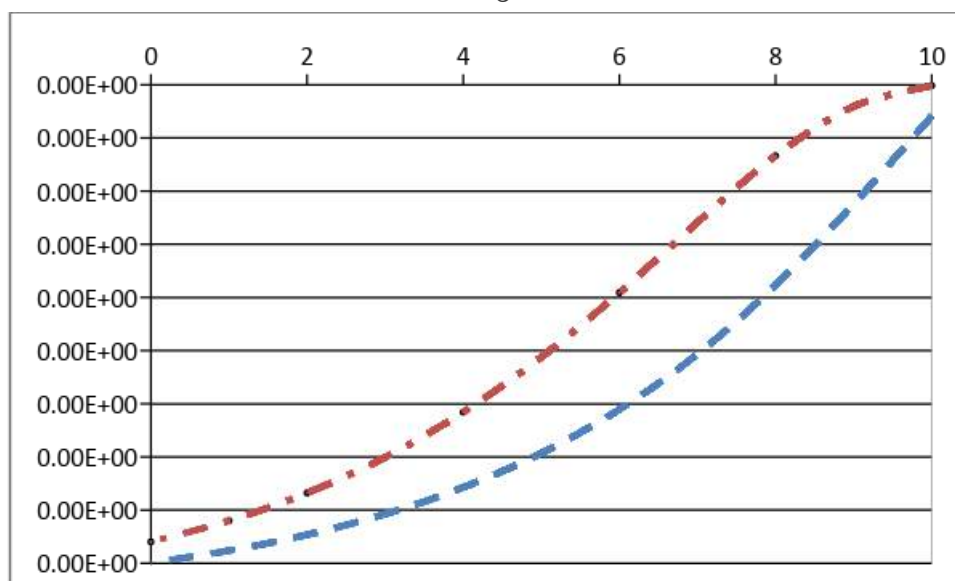

Figure 8: Relation between powers input (dBm) and power output with BER at using two types of pulse generators RZ and NRZ.

From researches experiments of this results of BER it seems using APD and RZ in like this system design is very good stable in communications, which is needed .

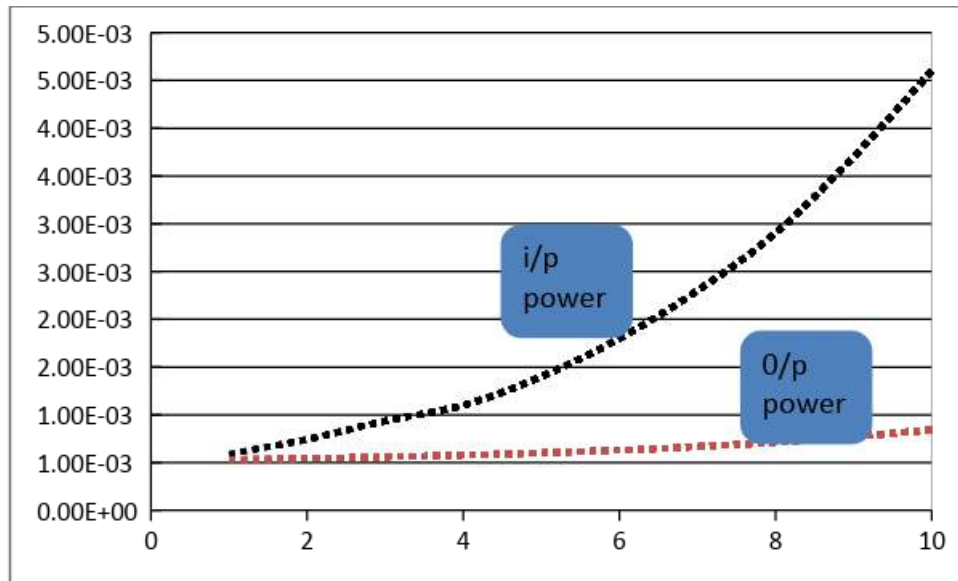

Figure 9: Relation between input power and out power

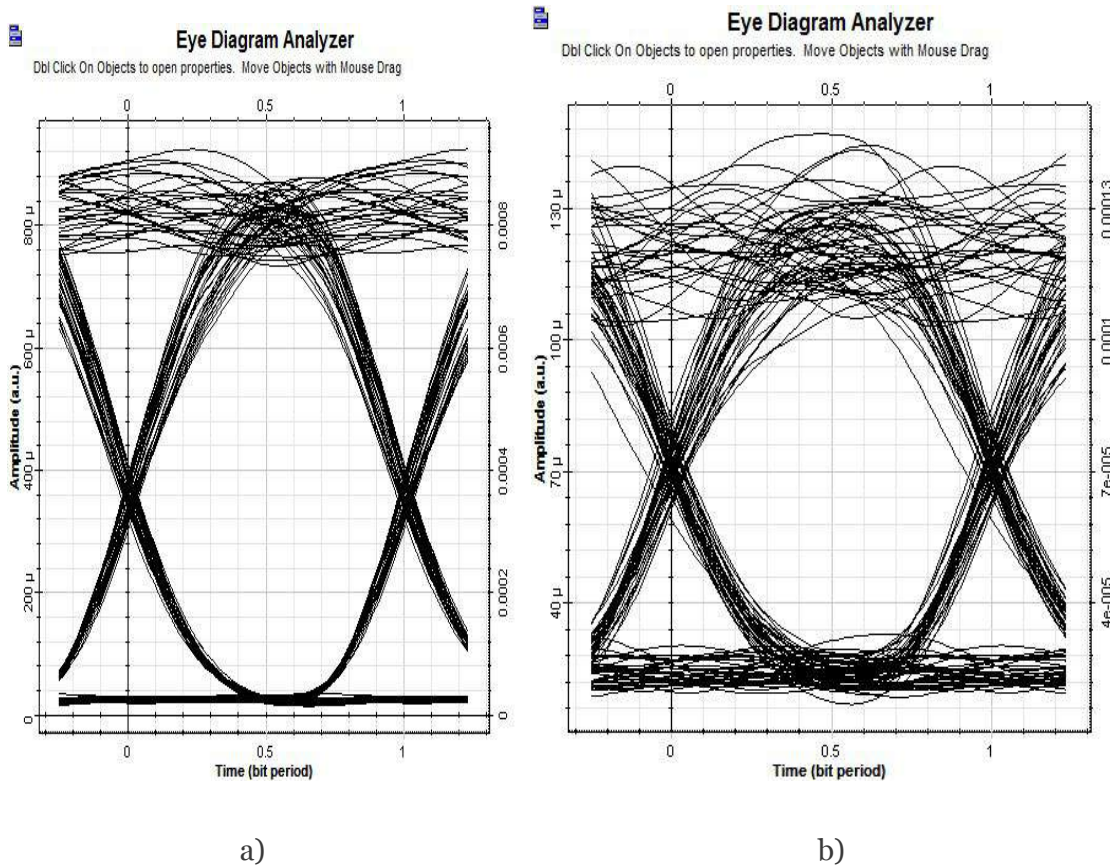

Figure 10: Eye diagrams shapes at first designed system

- a) 10 dBm input power using NRZ pulse generator and PIN photodiode Equal to  $1.51 \times 10^{-121}$ .
- b) 1 dBm input power using NRZ pulse generator and PIN photodiode equal to  $1.06 \times 10^{-19}$

From figure 10 the eye diagram gives a quick examination of the quality of the optical signal. It's clearly depicted that the EDW code system gives a better performance, having a large eye opening. The vertical distance between the top of

the eye-opening and the maximum signal level gives the degree of distortion. More the eye closes; the more difficult it is to distinguish between 1s and 0s in the signal. Hence in our results in the low data rate the eye patterns will be

equal to  $1.51e^{-121}$  for 10 Gpbs, while BER at high data rate will be equaled to  $1.06e^{-19}$  at 10 Gpbs. Referring to the Figure 8(a) and (b) respectively.

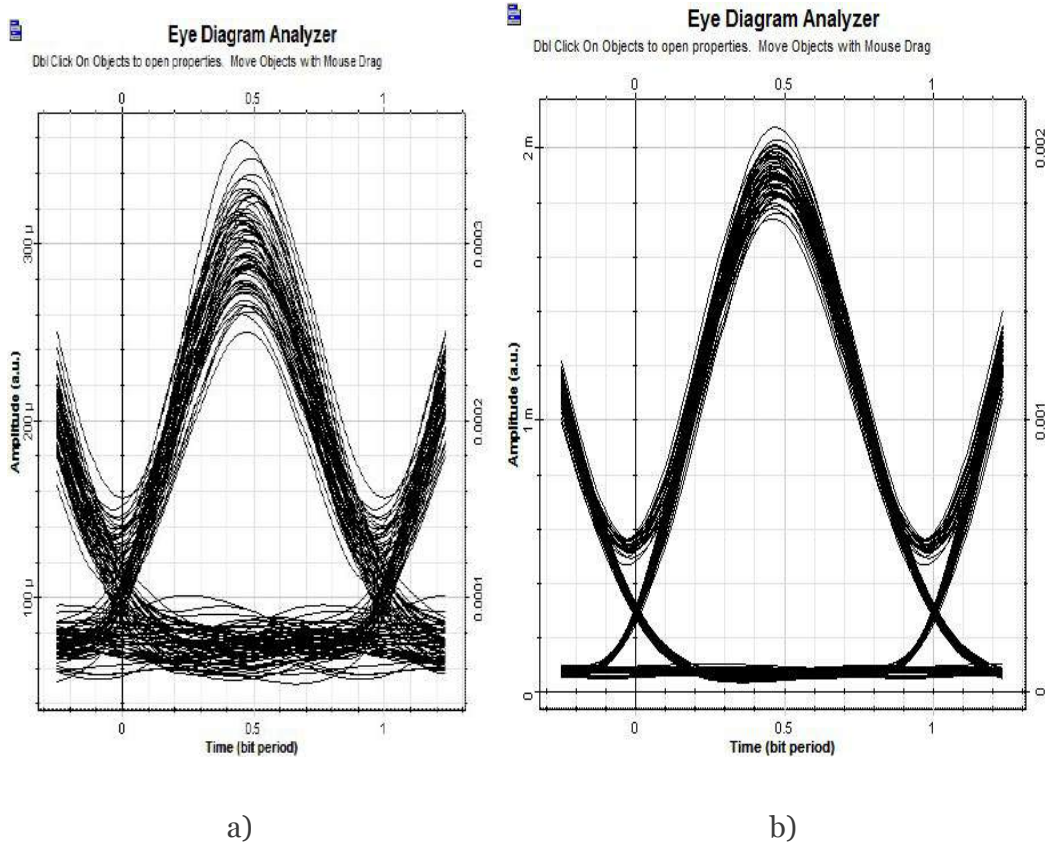

Figure 11: Eye diagrams at second designed system:

- a) 1 dBm input power using RZ pulse generator and APD photodiode equal to  $1.1 e^{-12}$ .
- b) 10 dBm input power using RZ pulse generator and APD photodiode equal to  $2.2 e^{-114}$ .

The description of figure 10 is the same illustration as for the figure 11. The Eye diagram analyze device is the best method used to check the system design's stability.

## II. CONCLUSION

By using different types of devices in many systems designed. it is very important thing to find which system of them is better than the other. The practical results taking directly from system designed by the help of software optisys.version 7.

## REFERENCES

1. K.Tajima, L.M.Washio, Opt.Lett.10 (9) (1985) 460.
2. T.L. Koch, R.C. Alferness, J. Light wave Technol. LT-3,(1985) 800.
3. C.Peuchere t, N.Hanik, R.Freund, L.Molle, P.Jeppesen, IEEE Photon.Technol.Lett.12 (8) (2000) 992.
4. Eugene A. Irene, ELECTRONIC MATERIALS SCIENCE, University of North Carolina, 2005.
5. Muthana. Y. Aldouri, American Scientific Research Journal for Engineering, Technology, and Sciences (ASRJETS), (2017) Volume 38, No 2, pp 300-310.
6. J C Palais," Fiber Optic Communications", 2nd Edition, PHI OF Cable Installation and external plant for TTA 2008 [BSNL]