



IMAGE: A MAP OF THE STARS OF THE ORION CONSTELLATION

Print ISSN: 2631-8474 Online ISSN: 2631-8482

JournalPreview

London Journal of Engineering Research

Volume 20 | Issue 2 | Compilation 1.0



JournalPreview

LONDON JOURNAL ENGINEERING RESEARCH

This document is a pre-published view of London Journal of Engineering Research Volume 20, Issue 2 and Compilation 1.0. For any minor changes and updations kindly follow your paper's live editing URL given in sent email or get in touch with our support team at support@journalspress.com or visit our website to use live chat support. This is a beta document thus order, content or existence of papers may alter in the published eJournal. You are requested to kindly acknowledge and approve your research paper in this JournalPreview within three days.

Journal Content

In this Issue



London
Journals Press

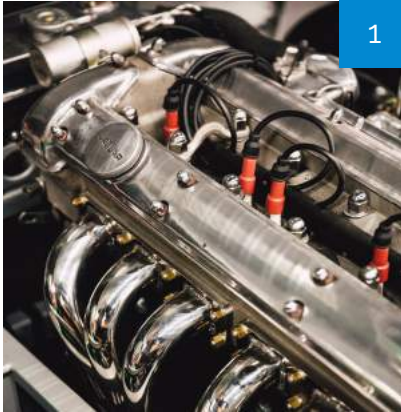

- i. Journal introduction and copyrights
 - ii. Featured blogs and online content
 - iii. Journal content
 - iv. Editorial Board Members
-



1. Design of Six-Stroke Internal Combustion Spark Ignition...
pg. 1-14
 2. Strengths of India Related to E-Mobility
pg. 15-30
 3. Alternative to the Maxwell Equations
pg. 31-40
 4. I-Clean of Cabin Air Con Filter
pg. 41-44
-

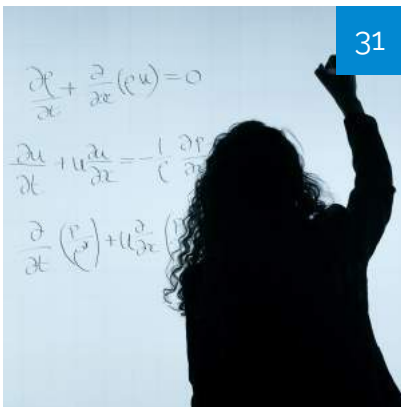

- V. London Journals Press Memberships



Scan to know paper details and
author's profile

Design of Six-Stroke Internal Combustion Spark Ignition Engine

A.b. Hassan & M.a. Olabiyi

Federal University of Technology

ABSTRACT

The rate at which energy is lost by human activities is enormous. There is need to work on how to generate more energy and minimize the usage of the generated energy. In an internal combustion engine, there is a need to focus on gaining energy usage by using generated heat during the combustion process. To reduce the energy usage, emission rate and improve the efficiency of four-stroke internal combustion spark ignition engine, the four-stroke internal combustion spark ignition engine is modified into a six-stroke internal combustion spark ignition engine. The heat generated from a four-stroke cycle is used in a six-stroke cycle for additional power stroke and exhaust stroke of the piston in the same cylinder. There is an injection of water which forms steam with the help of generated heat from a four-stroke cycle which forces down the piston for additional power stroke and the piston comes up to expel the exhaust gases out of the cylinder. With the injection of water into the cylinder, there is no need for a cooling system as in a four-stroke Otto cycle which makes the engine become lighter and 25% fuel and power efficiency over the normal Otto cycle.

Keywords: six-stroke, spark ignition, internal combustion, cam shaft, crankshaft, sprocket.

Classification: FOR Code: 090201

Language: English



LJP Copyright ID: 392992

Print ISSN: 2631-8474

Online ISSN: 2631-8482

London Journal of Engineering Research

Volume 20 | Issue 2 | Compilation 1.0



© 2020. A.b. Hassan & M.a. Olabiyi. This is a research/review paper, distributed under the terms of the Creative Commons Attribution-Noncom-mercial 4.0 Unported License <http://creativecommons.org/licenses/by-nc/4.0/>, permitting all noncommercial use, distribution, and reproduction in any medium, provided the original work is properly cited.

Design of Six-Stroke Internal Combustion Spark Ignition Engine

A.b. Hassan^α & M.a. Olabiyi^σ

ABSTRACT

The rate at which energy is lost by human activities is enormous. There is need to work on how to generate more energy and minimize the usage of the generated energy. In an internal combustion engine, there is a need to focus on gaining energy usage by using generated heat during the combustion process. To reduce the energy usage, emission rate and improve the efficiency of four-stroke internal combustion spark ignition engine, the four-stroke internal combustion spark ignition engine is modified into a six-stroke internal combustion spark ignition engine. The heat generated from a four-stroke cycle is used in a six-stroke cycle for additional power stroke and exhaust stroke of the piston in the same cylinder. There is an injection of water which forms steam with the help of generated heat from a four-stroke cycle which forces down the piston for additional power stroke and the piston comes up to expel the exhaust gases out of the cylinder. With the injection of water into the cylinder, there is no need for a cooling system as in a four-stroke Otto cycle which makes the engine become lighter and 25% fuel and power efficiency over the normal Otto cycle.

Keywords: six-stroke, spark ignition, internal combustion, cam shaft, crankshaft, sprocket.

Author α σ : Department of Mechanical Engineering, Federal University of Technology, P.M.B.65, Minna, Niger State, Nigeria.

I. INTRODUCTION

The six-stroke internal combustion spark ignition engine principle is based on the conventional four-stroke internal combustion spark ignition

engine but with additional features for energy saving (fuel consumption), maximum power optimization, and cooling rate e.t.c. The additional features includes the addition of other two strokes in which the engine uses the waste heat from the four-stroke internal combustion spark ignition engine (Otto cycle or Diesel cycle) for additional power stroke and exhaust stroke of the piston in the cylinder. The design uses steam as working fluid for the additional power stroke.

1.1 Background of the Study

In an internal combustion engine, most of the fuels energy is lost as heat and as pollutant. The heat is aired out by the radiator. There is need to concentrate on the rate of energy loss as the world is working on how to generate more energy and minimize the usage of already generated energy. The consequence of energy cannot be overemphasized in the view of human technology; every aspect of human endeavor requires a consistent and viable source of energy and how to maintain it. There is need to focus on gaining of energy by the usage of this heat generated in the internal combustion engine. The six-stroke engine was developed since the 1990s, describes two different approaches in the internal combustion engine, to improve its efficiency and reduce emissions. The engine entrances the waste heat from the four-stroke of an internal combustion engine being Otto cycle or Diesel cycle and uses it to get an additional power and exhaust stroke of the piston in the same cylinder. Designs either use steam or air as the working fluid for the additional power stroke. The additional stroke cools the engine and removes the need for a cooling system making the engine lighter and giving 40% increased efficiency over the normal Otto cycle or

Diesel Cycle (Ahmad, 2012). The pistons in this six-stroke engine go up and down six times for each injection of fuel. These six-stroke engines have two power strokes: one by fuel, one by steam or air. The currently notable six-stroke engine designs in this class are the Crower's six-stroke engine, invented by Bruce Crower of the U.S.A; the Bajulaz engine by the Bajulaz S A Company, of Switzerland; and the Velozeta's Six-stroke spark ignition engine built by the College of Engineering, at Trivandrum in India.

The second approach to the six-stroke internal combustion spark ignition engine uses a second opposed piston in each cylinder which moves at half the cyclical rate of the main piston, thus giving six piston movements per cycle. Functionally, the second piston replaces the valve mechanism of a conventional engine and also it increases the compression ratio. The currently notable six-stroke spark ignition engine designs in this class include two designs developed independently: The Beare Head engine, invented by Australian farmer Malcolm Beare, and the German Charge pump, invented by Helmut Kottmann.

1.2 Strokes of Four-Stroke Spark Ignition Engine

The working principle of the four-stroke spark ignition engine:

- *First Stroke:* Here, the inlet valve opens for the air-fuel mixture from the carburetor which is sucked into the cylinder through the inlet manifold.
- *Second stroke:* The second stroke of the internal combustion engine which is the compression stroke, the piston moves from Bottom Dead Centre (BDC) to the Top Dead Centre (TDC) to compress the air-fuel mixture in which both the inlet and outlet valve were closed.
- *Third stroke:* This is the power stroke on an internal combustion engine in which the compressed air-fuel mixture is ignited by the spark plug. The two valves remain closed and

the piston is forced down from Top Dead Centre (TDC) to Bottom Dead Centre (BDC).

- *Fourth stroke:* The fourth stroke of an internal combustion engine is the exhaust stroke where the exhaust (outlet) valve opens to allow the exhaust (burned gases) out of the engine cylinder. Here, the piston moves from the Bottom Dead Centre (BDC) to the Top Dead Centre (TDC) and the inlet valve remain closed.

1.3 Strokes of a Six-stroke Spark Ignition Engine

- *Fifth stroke:* In the fifth stroke of an internal combustion engine the piston is force down by the heat generated at the exhaust stroke and the steam formed by the injection of water under pressure and temperature through the water injection nozzles into the cylinder. The piston is forced down from the Top Dead Centre (TDC) to the Bottom Dead Centre (BDC) for the second power stroke.
- *Sixth stroke:* This is the second exhaust cycle where the piston moves from the Bottom Dead Centre (BDC) to the Top Dead Centre (TDC). The exhaust valve opens for the passage of gases out of the cylinder.

II. RESEARCH METHODOLOGY

2.1 Six-Stroke Engine

This Design uses steam as a working fluid for the additional power stroke as well as extracting power; the additional stroke cools the engine and removes the cooling system of the engine making the engine lighter and increased efficiency over the Otto cycle.

2.2 Additional Strokes Introduce

- *Fifth stroke:* At the fifth stroke which is the first additional stroke out of the two strokes added to the four-stroke of an internal combustion engine, the heat evolved at the exhaust of the forth cycle were use directly. There is intake of water by water injection into the super-heated cylinder, the water explodes

into steam then forces the piston down for the second power stroke. This also cools the engine. The water injection consist of three main components; injector, water pressurizing system and electronic control system.

- *Sixth stroke:* All the vapors at the top of the piston inside the cylinder and gases are thrown

out from the combustion chamber through the exhaust valve and water vapor can be collected by a condenser which is attached to the exhaust port so that the water can be reused. The processes are explained in the figure 2.1 below:

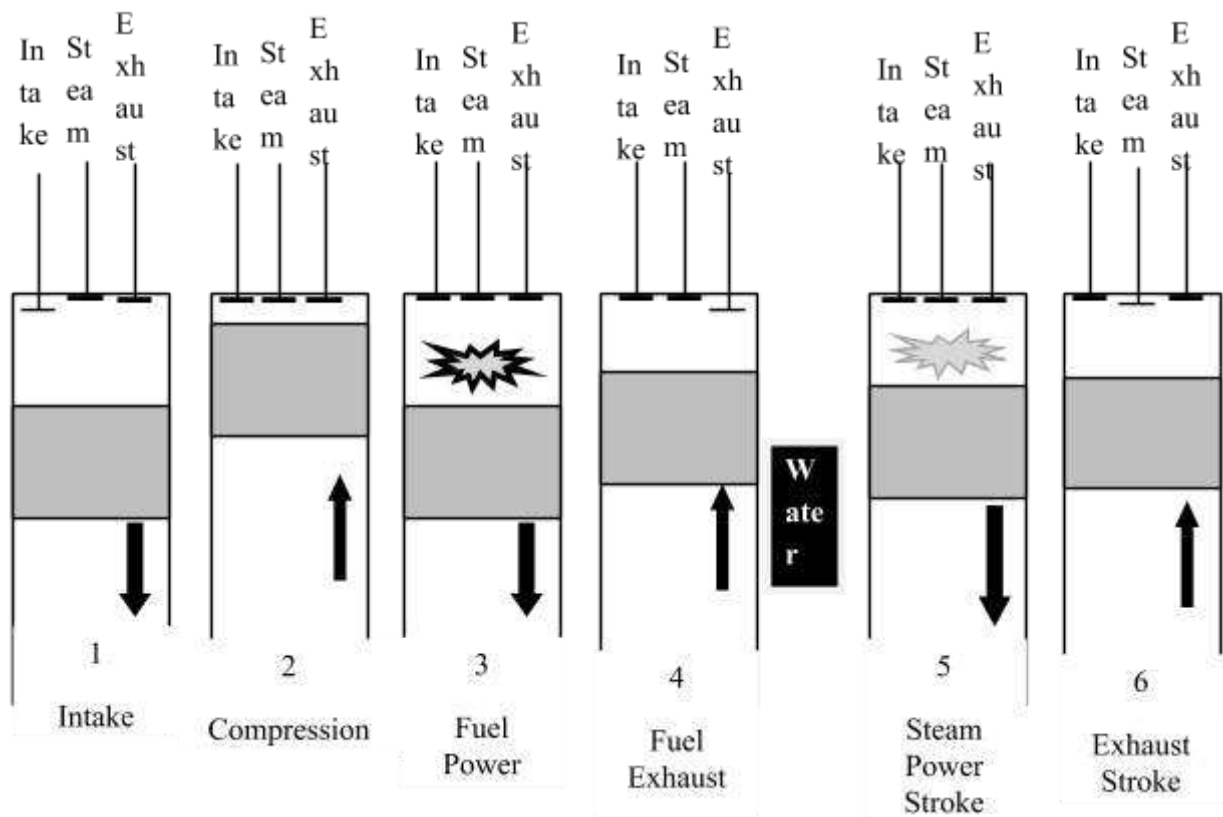

Figure 2.1: Analysis of Strokes in Six-Stroke Internal Combustion Engine

2.3 Engine Modification of Four-Stroke Spark Ignition Engine:

The conventional four-stroke engine was modified by working on some specific part for the addition of two more strokes for additional power to the four-stroke engine. These modifications are:

2.3.1 Camshaft/Crankshaft sprocket

Camshaft is a rod or shaft to which cams are attached. Cams are non-circular wheels, which operate the cylinder valves of an internal

combustion engine and are also used to operate other gear-driven engine components. Camshaft design can determine whether the camshaft can help the engine to produce heavy torque. The cams on the camshaft operate the intake and exhaust valves of the engine. The original angular speed of the camshaft is one-half that of the crankshaft, such that the camshaft rotates once for every two revolutions (four-stroke) of the crankshaft. The six-stroke camshaft has been designed to turn one revolution every three revolutions (six-stroke) of the crankshaft.

In an internal combustion engine, camshaft is a cylindrical rod running at the length of the cylinder bank with a number of a long lobes protruding from it, one for each valve. The cam lobes force the valve open by pressing on the valve as they rotate. The main function of camshaft is to operate poppet valve

In 2-stroke engine,
If there is two stroke of the piston and one revolution (360°) of the camshaft, the revolution of the crankshaft of the two stroke of the piston in degree will be:

$$\frac{2 \times 360}{2} = \frac{720}{2} = 360^\circ \text{ revolution of crankshaft}$$

For 2 –stroke, power stroke occurs once in every 360° revolution of crankshaft

For 4-stroke engine,

If firing takes place once after every 4-stroke

$$\frac{4 \times 360}{2} = \frac{144}{2} = 720^\circ \text{ revolution of crankshaft}$$

For 6 – stroke engine,

If power will occur once in every

$$\frac{6 \times 720}{4} = \frac{4320}{4} = 1080^\circ \text{ revolution of crankshaft}$$

Therefore the corresponding sprocket of four strokes to six-stroke having teeth ratio 720°: 1080°

This gives ratio 1:3

This makes it necessary to keep the camshaft pulley three times bigger than crank shaft pulley for the 6- stroke engine.



Figure 2.2: The unmodified and modified crank and cam shaft gear teeth (Shubham, 2016)

2.3.2 Camshaft Modification

In a six stroke internal combustion engine, the 360° cam was divided into six, the exhaust has two (2) lobes, one to open the exhaust valve at the forth stroke and at the sixth stroke to push out the steam.

2.3.3 Timing Gear

The gear train (sprocket) with two to one reduction through which the crankshaft drives the camshaft and controls valve timing in an internal combustion spark ignition engine. The timing gear of a four-stroke internal combustion spark

ignition engine consists of 32 teeth with a cam revolution ratio of 1:2.

If for every two rotations of a crank, the timing gear rotates a single rotation. The timing gear of a six-stroke internal combustion spark ignition engine will consists of

$$\frac{1}{2} \times 32 = 16$$

$$16 \times 3 = 48$$

.48 teeth with a cam revolution ratio of 1:3. Here for every three rotations of a crank the timing gear rotates a single rotation.

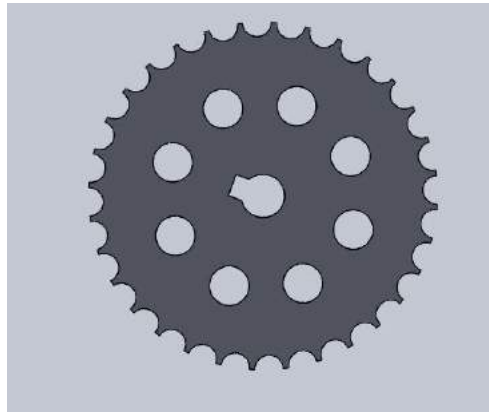

Figure 2.3: Sprocket of Four-Stroke Engine. (Arul, 2017)

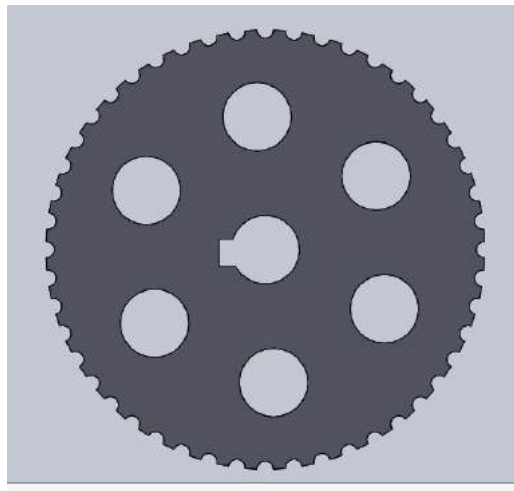

Figure 2.4: Sprocket of a Six-Stroke Engine.

2.3.4 Cam Profile Design

2.3.5 The design of the cam profile is very vital and it will be design on the basis of the following

- The distance that the valve will move toward the piston
- The time for the valve to remain open for exhaust gases

- The time it will take for the closing of the valve which is the same as that of opening time

The four-stroke camshaft profile: the four-stroke camshaft has a 90° of design in angle; the circle was divided into four.

The camshaft has two lobes, one for intake valve and one for exhaust valve

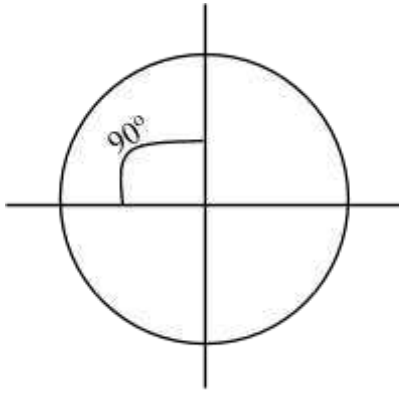

Figure 2.4: Cam Lobe of Four-Stroke Engine (Mohd, 2012)

2.3.5.1 Six-stroke Camshaft Profile

The six-stroke camshaft profile has a 60° design of an angle; the circle was divided into six.

camshaft has four lobes, two for the intakes valve (for the intake of air-fuel mixture), two to allow injection of water at the fifth stroke and two for the exhaust valve (for the first exhaust after the combustion and for the second exhaust of the steam after the fifth stroke)

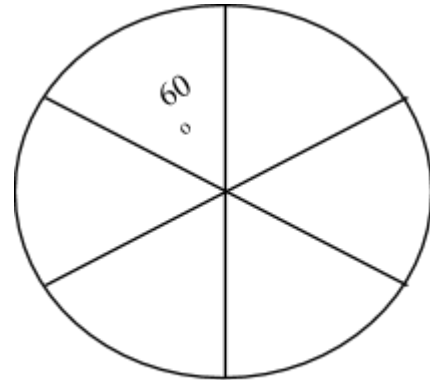

Figure 2.5: Cam lobe shape of six-stroke engine

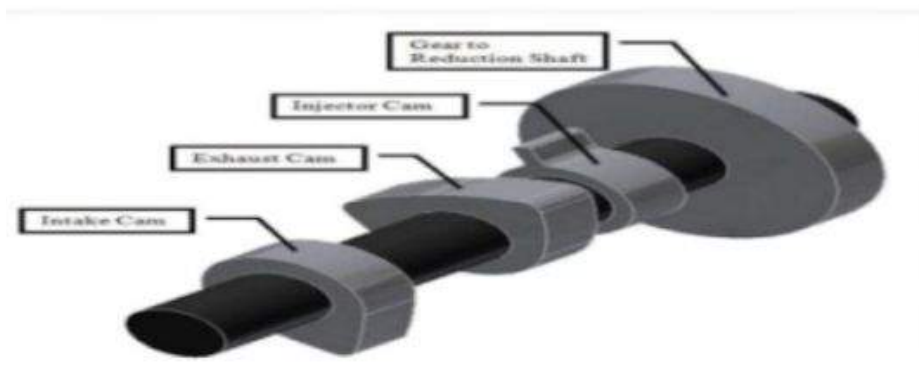

Figure 2.6: Six-stroke Flat and Spherical Camshaft Follower (Saurabh, 2015)

2.4 Fuel Tank

The fuel tank of four-stroke internal combustion spark ignition engine has to be divided into two for the six-stroke internal combustion spark ignition engine as one side is for fuel and the other will be for water and the water has to be distill and pure.

2.5 Cam Follower Modification

The four-stroke internal combustion spark ignition engine has its bottom shape follower in flat pattern. For the six-stroke internal combustion spark ignition engine, the follower has to be in roller or spherical shape has its contact area is lesser.

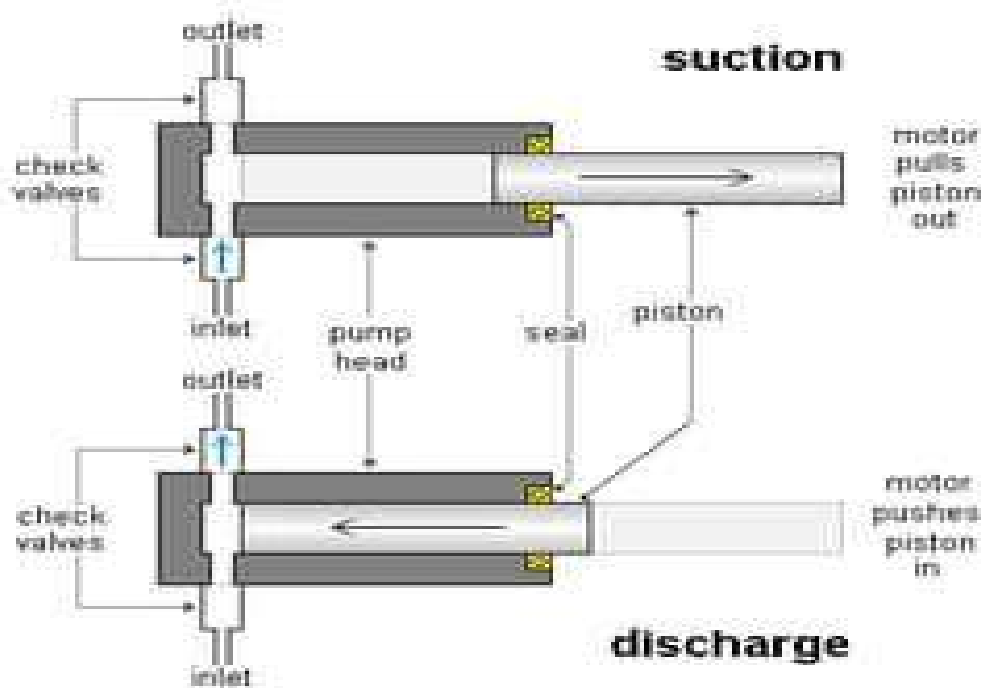

Figure 2.7: Water Metering Pump

2.6 Injection of Water System

The injection of the water system is done with the help of a water injector operated by the cam. This can be achieved with the use of a water metering pump. The water metering pump is a positive displacement pump capable of driving a fixed quantity of water into the cylinder at regular intervals independent of the back pressure applied.

2.7 Analysis of Internal Combustion Spark Ignition Engine

2.7.1 Indicated Power

The indicated power can be defined as the power remaining to drive the piston after some are loss to the coolant, radiation and exhaust

For four-stroke engine n : the indicated power is thus.

$$I_p = \frac{P_m \times L \times A \times N}{60 \times 1000} \quad (2.1)$$

Where:

i_p = indicated power (kW)

P_m = indicated mean effective pressure

n = is the number of power stroke

$N = \frac{N}{2}$ and N = speed of the engine (r.p.m)

L = length of the stroke (m)

A = cross – sectional area of the piston (m²)

For four-stroke engine, since $N = N/2$

Therefore substitute for the value of n

$$I_p = \frac{i_{mep} \times L \times A \times N/2}{60 \times 1000} \quad (2.2)$$

$$= 8.333 \times 10^{-6} i_{mep} L A N \quad (2.3)$$

For six-stroke engine n : the indicated power is as follows:

$$I_p = \frac{i_{mep} \times L \times A \times N}{60 \times 1000} \quad (2.4)$$

Where $N = \frac{2N}{3}$

$$I_p = \frac{i_{mep} \times L \times A \times 2 \times N}{60 \times 1000 \times 3} = 1.111 \times 10^{-5} i_{mep} L A N \quad (2.5)$$

2.7.2 Percentage Difference in Indicated Power

The percentage difference in the indicated power of four-stroke internal combustion spark ignition engine and the six-stroke internal combustion spark ignition engine may be calculated as:

$$\% = \frac{ip \text{ of six-stroke} - ip \text{ of four-stroke}}{ip \text{ of six-stroke}} \times \frac{100}{1} \quad (2.6)$$

From equation (3.3) and equation (3.5)

$$\% = \frac{1.111 \times 10^{-5} i_{mep} LAN - 8.333 \times 10^{-6} i_{mep} LAN}{1.111 \times 10^{-5} i_{mep} LAN} \times \frac{100}{1} = 25\%$$

2.7.3 Break Power

Is the useful power transmitted by the piston to the crankshaft

$$B.P = \frac{2\pi NT}{60 \times 10^3} \quad (2.7)$$

Where BP = Break Power

T = Torque (Nm)

N = $\frac{N}{2}$ for 4 stroke engine

N = speed of the engine (r.p.m)

Assuming the Torque to be 58Nm, N to be 900 r.p.m

For four-stroke internal combustion spark ignition engine

$$B.P_4 = \frac{2\pi NT}{60 \times 10^3}$$

$$B.P_4 = 2.73 \text{ W}$$

For six-stroke internal combustion spark ignition engine where N = $\frac{2N}{3}$

$$B.P_6 = \frac{2\pi NT}{60 \times 10^3} \quad (2.9)$$

$$B.P_6 = 3.64 \text{ W}$$

2.7.4 Percentage Difference in Break Power

The percentage difference in the break power of four-stroke internal combustion spark ignition engine and the six-stroke internal combustion spark ignition engine may be calculated as:

$$\% = \frac{bp \text{ of six-stroke} - bp \text{ of four stroke}}{ip \text{ of six stroke}} \times \frac{100}{1} \quad (2.10)$$

From the result of equation 3.7 and equation 3.8, the percentage difference can be calculated as:

$$\% = \frac{3.64 - 2.73}{3.64} \times \frac{100}{1} = 25\%$$

2.7.5 Mechanical Efficiency

The mechanical efficiency can be defined as the ratio of the brake thermal efficiency to indicated thermal efficiency.

$$\eta_{th} = \frac{bp}{ip} \quad (2.11)$$

2.7.6 Thermal Efficiency

The thermal efficiency can be defined as the ratio of the power produced to the energy in the fuel burned to produce this power. It can be expressed as follows:

$$\eta_{th} = \frac{P}{\dot{m}_f Q_f} \quad (2.12)$$

Where \dot{m}_f = fuel mass flow rate

Q_f = calorific value of fuel

$$\text{And } Q_f = \frac{\text{Heat Produced (kJ)}}{\text{Amount of fuel used (kg)}}$$

Where P can be either break power or indicated power, therefore

$$\eta_{bth} = \frac{bp}{\dot{m}_f Q_f}; \quad (2.13)$$

$$\text{Fuel Consumption } \dot{m}_f = \frac{v_f}{t_f} \times \rho_f \quad (2.14)$$

v_f = Volume of fuel (m³)

t_f = Fuel consumption time (sec)

ρ_f = Density of fuel kg/m³

Let Q_f of gasoline = 46400kJ/kg

ρ_f of gasoline = 737kg/m³ and

take Torque to be 58Nm

η_{bth} = Break Thermal Efficiency

2.8 Percentage Useful Power Stroke

In four-stroke internal combustion spark ignition engine there is only one useful power stroke and other three strokes idle, the percentage useful power stroke may be calculated as

$$\% \text{ useful power stroke} = \frac{\text{number of power stroke}}{\text{number of stroke}}$$

Where number of useful power stroke = 2

$$\begin{aligned} \text{Number of stroke} &= 4 \\ &= 0.25 \times 100 \\ &= 25\% \end{aligned}$$

While:

In six-stroke internal combustion spark ignition engine, there is two useful power stroke and four stroke being idle, the percentage useful may be calculated as % useful power stroke =

$$\frac{\text{number of power stroke}}{\text{number of stroke}}$$

Where number of useful power stroke = 2

$$\begin{aligned} \text{Number of stroke} &= 6 \\ &= \frac{2}{6} \times \frac{100}{1} \\ &= 0.333 \times 100 \\ &= 33.3\% \end{aligned}$$

2.8.1 Percentage Difference of Useful Power Stroke

The percentage difference of the useful power stroke of four-stroke internal combustion spark

ignition engine and the six-stroke internal combustion spark ignition engine may be calculated as:

$$\% = \frac{\% \text{ useful stroke of six-stroke} - \% \text{ useful stroke of four stroke}}{\% \text{ useful stroke of six stroke}} \times \frac{100}{1} \quad (2.15)$$

From the result of equation 3.7 and equation 3.8, the percentage difference can be calculated as:

$$\begin{aligned} \% &= \frac{33.3 - 25}{33.3} \times \frac{100}{1} \\ &= 24.9\% \\ &\approx 25\% \end{aligned}$$

2.9 Piston Movement of Six-Stroke Engine

For six-stroke engine, the movement of the piston continues at the fourth stage of the four-stroke engine. The piston moves from the Top Dead Centre to Bottom Dead Centre for another expansion which occurs between the top and Bottom Dead Centre at 450° of the camshaft 900° crankshaft.

The last movement of the piston for six-stroke engine is from Bottom Dead Centre to Top Dead Centre for the second exhaust of gas at 540° of the camshaft 1080° crankshaft.

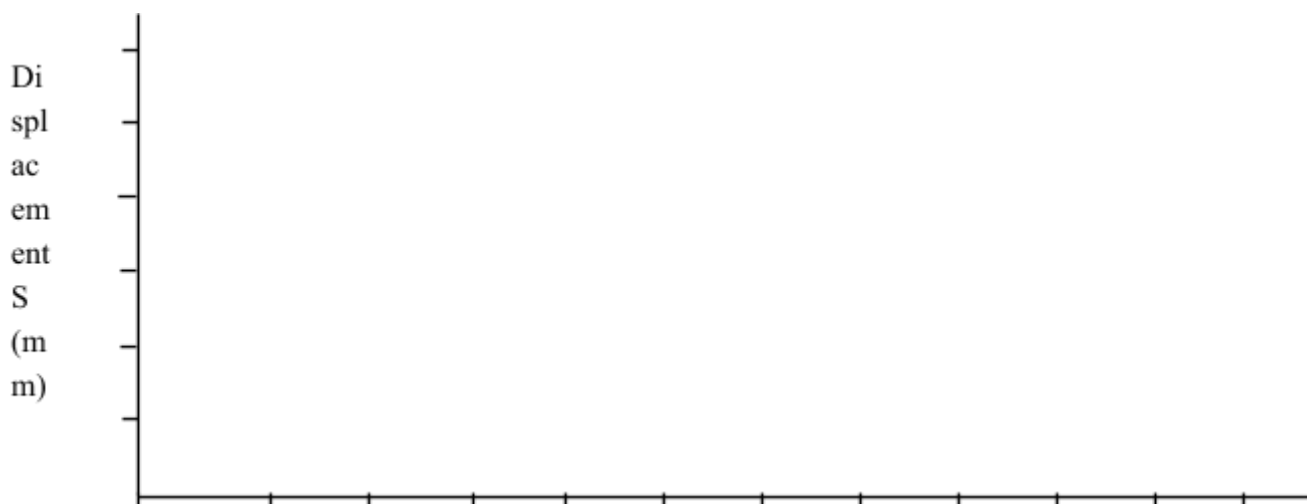

Figure 2.8: Angle of crankshaft of Six- Stroke Engine

III. RESULTS

3.1 Thermal Efficiency

The thermal efficiency can be defined as the ratio of the power produced to the energy in the fuel

burned to produce this power. Using equation (2.13) and (2.14) the result of break thermal efficiency for four-stroke engine and six-stroke engine are shown in the table 3.1 and 3.2

Table 3.1: Result of Raw Data for Break Thermal Efficiency of Four-Stroke Engine Calculation

S/No	Assumption	1	2	3	4	5
1	Load W (kg)	0	0	0	0	0
2	Speed N (r.p.m.)	900	1200	1500	1800	2000
3	Volume of fuel (m ³)	0.00001	0.00001	0.00001	0.00001	0.00001
4	Fuel consumption time (sec)	42	34	30	26	24
	N for 4 stroke	0.5	0.5	0.5	0.5	0.5
	Torque = 58Nm	58	58	58	58	58
	caloric value of fuel = 46400kJ/kg	46400	46400	46400	46400	46400
	Density of fuel kg/m ³ = 737kh/m ³	737	737	737	737	737
	Break Power	2.73354	3.64472	4.5559	5.46708	6.074533
	fuel mass flow rate	0.000175	0.000217	0.000246	0.000283	0.000307
	Break Thermal Efficiency %	33.57293	36.23745	39.96777	41.56649	42.63229

Table 3.2: Result of Raw Data for Break Thermal Efficiency_y of Six-Stroke Engine Calculation

S/No	Assumption	1	2	3	4	5
1	Load W (kg)	0	0	0	0	0
2	Speed N (r.p.m)	900	1200	1500	1800	2000
3	Volume of fuel (m ³)	0.00001	0.00001	0.00001	0.00001	0.00001
4	Fuel consumption time (sec)	42	34	30	26	24
	N for 6 stroke	0.666667	0.666667	0.666667	0.666667	0.666667
	Torque = 58Nm	58	58	58	58	58
	caloric value of fuel = 46400kJ/kg	46400	46400	46400	46400	46400
	Density of fuel kg/m ³ = 737kh/m ³	737	737	737	737	737
	Break Power	3.64472	4.859627	6.074533	7.28944	8.099378
	fuel mass flow rate	0.000175	0.000217	0.000246	0.000283	0.000307
	Break Thermal Efficiency %	44.76391	48.3166	53.29037	55.42198	56.84306

Table 3.3: Six-Stroke and Four-Stroke Data for Brake Efficiency

Brake Thermal Efficiency		
Speed N (r.p.m)	4-stroke %	6-stroke %
900	33.57	44.76
1200	36.24	48.32
1500	39.97	53.29
1800	41.57	55.42
2000	42.63	56.84

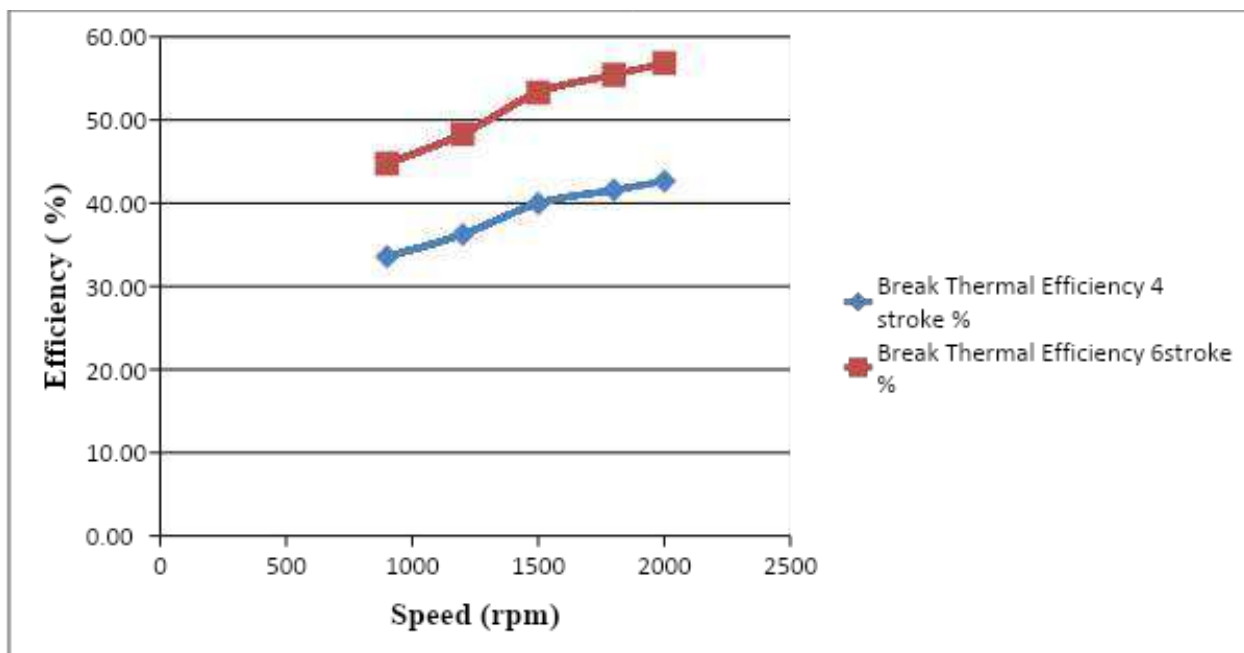

Figure 3.1: Efficiency (%) of Four-Stroke and Six-Stroke Engine

3.2 Pressure – Volume of Six-Stroke Engine

The constant volume cycle (Otto cycle) volume of six-stroke internal combustion spark ignition engine continue from the fourth stage of the normal convention of the four-stroke internal combustion spark ignition engine. The resulting pressure -volume diagram for the six-stroke internal combustion spark ignition engine is shown in figure 3.2.

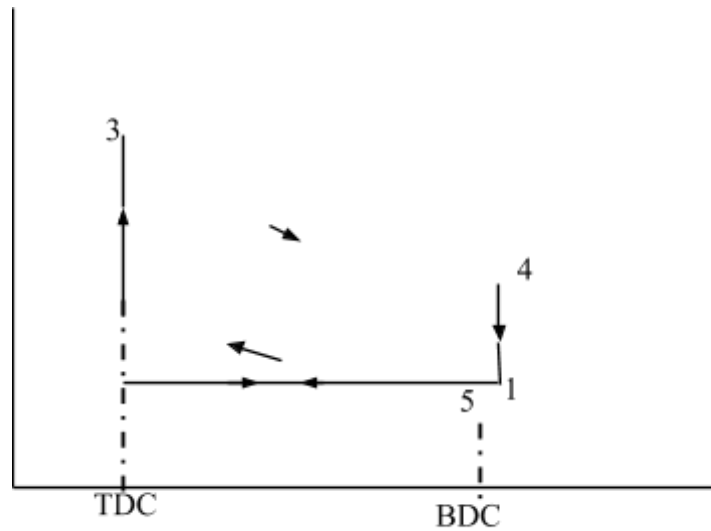

Figure 3.2: P-V diagram of six-stroke engine

3.3 Percentage Differences in Power

The output power percentage differences of four-stroke internal combustion spark ignition

engine and the six-stroke internal combustion spark ignition engine using equation are shown in table 3.4 below:

Table 3.4: Six-Stroke and Four-Stroke Output Percentage Differences

S/NO	Power	Percentage Differences (%)
1	Indicated Power	25 %
2	Break Power	25%
3	Useful Power Stroke	25%

3.4 Discussion of Analysis of Internal Combustion Spark Ignition Engine

From equations (2.3) and (2.5), it shows that some of the power produced in the cylinder to drive the piston after combustion are loss to radiation and exhaust of the six-stroke internal combustion spark ignition engine is more than that of four-stroke internal combustion spark ignition engine as the six-stroke requires no cooling system. Also the results from equations (2.8) and (2.9) implies that the power transmitted from the piston to drive the crankshaft is greater than that of four-stroke internal combustion spark ignition engine which gives the six-stroke internal combustion spark ignition engine a greater output (speed) with the same energy (fuel) burned resulting in reduction of fuel burned with the same distance covered of about 25%.

Table 3.4 shows that the six-stroke internal combustion spark ignition engine is of 25% power efficiency than that of four-stroke internal combustion spark ignition engine.

IV. CONCLUSION AND RECOMMENDATION

4.1 Conclusion

The introduction of six-stroke internal combustion spark ignition engine has positive impact in the world economy as it reduces the rate of energy consumption, and reduces the rate of polluting the environment with exhaust flame. The temperature of the engine is lower due to the injection of water which improved the cooling system and increases its overall efficiency. With all the desired qualities and modification, the six-stroke internal combustion spark ignition engine is better than the four-stroke internal combustion spark ignition engine.

4.2 Recommendation

This project design should be recommended for further research base on the material properties that is of thermal resistant alloys as the components will be subjected to thermal stresses that will be developed due to water injection into the superheated cylinder in which the rapid temperature changes can cause fracture or micro cracking at low cost.

REFERENCES

1. Ahmad, A.A. (2012). Thermodynamics Analysis for a Six-stroke Engine for Heat Improvement. Faculty of Mechanical Engineering University Pahang Malaysia.
2. Arul, J., Georgen, J., Rangan, R., Soundar, S., & Thamilarasan, V. (2017). Design and Experimental Investigation of Modified Four Stroke to Six Stroke Cam Profile. Department of Mechanical, Vel Tech, Chennai, Tamilnadu, India.
3. Bajulaz, R.A. (1985). Method for the transformation of thermal energy into mechanical energy by means of a combustion engine as well as this new engine. 825 Las Palmas Dr., Hope Ranch, Santa Barbara, Calif. Switzerland
4. Chinmayee, K., & Vivek, R. (2014). Analysing the Implementation of Six-stroke Engine in a Hybrid Car. International Journal of Mechanical Engineering and Applications. Vol. 2, No. 1, pp. 1-4. doi: 10.11648/j.ijmea.20140201.11.
5. Dharendra, P., Abhishek, S., Chirag, S., & Ritu, R. (2017). Review Six Stroke Engine. Mechanical and Automation, Amity University Greater Noida, India.
6. Gasim, M. M., Chui, L. G., & Bin, K. A. (2012). Six Stroke Engine Arrangement. Military Technical College Kobry El-Kobbah, Cairo, Egypt.
7. Justin, L.H. (2004). A Thermodynamics Based Model For Predicting Piston Engine Performance For Use In Aviation Vehicle Design.
8. Jovan, D., Ivan, K., Mark, D., (2011). Constant Volume Combustion Cycle for Internal Combustion Engine. Mechanical Department: Faculty of Technical Science Trg. Dositega ObradoVica 6, 21000 Novi Sad, Serbia.
9. Lukamn, N.M. (2012). Experimental Study of Six-stroke Engine For Heat Recovery Faculty of Mechanical Engineering University Pahang, Malaysia.
10. Mohad N.A (2012). Camshaft Design for a Six stroke Engine Faculty of Mechanical Engineering University Pahang, Malaysia.
11. Rajput, R.K. (2007). Engineering Thermodynamics: Punjab College of Information Technology Patiak Punjab. India 3rd Edition. Laxmi Publication, New Delhi, USA pg 633.
12. Rohit, R.(2016). A Review on Brown Crower"s Six Stroke Internal Combustion Engine Student. Department of Mechanical Engineering JSS Academy of Technical Education, Noida UP, India.
13. Saurabh, A. (2015). Seminar on Six Stroke Engine: Mechanical Engineering (Sandwich) of the Savitribai Phule, Pune University
14. Shubham, S., Shivender, P., Shivam, C., Gourav, D. (2016). Concept of Six Stroke Engine International Journal of Scientific & Engineering Research, Volume 7, Issue 5, ISSN 2229-5518.
15. Ujjwal, K.S. (2012). Internal Combustion Engine. Department of Mechanical Engineering, India Institute of Technology, Guwahati, India.

WEBSITES

- <http://www.bajulazsa.com/site/sixstrokeexplanations.html>
<http://www.velozetas.com/site/sixstrokeexplanations.html>

This page is intentionally left blank



Scan to know paper details and
author's profile

Strengths of India Related to E-Mobility

Satyendra Nath Saxena

ABSTRACT

India is importing a large percentage of petroleum products, and therefore in the interest of national energy security, it is essential for India to reduce the use of petrol and diesel-based vehicles and increase electrical vehicles on roads. Also, due to high levels of pollution in most of the Indian cities due to tail-pipe emissions from petrol and diesel vehicles, switching to electric mobility must be taken with increased efforts by the government and manufacturers. Supported by the policies of the government, there are great initiatives by many public sector and private organizations to gradually increase the number of charging stations for electric vehicles in cities and highways all over India. With availability of improved batteries, controllers and motors at lower costs in the coming 4-5 years, it is expected that the costs of all categories of EVs would come down to be competitive with the petrol and diesel-based vehicles. With ambitious plans of Indian Government to have power generation from renewable energy in the coming 10 years, the power demand for charging of electric vehicles can easily be met only from the newly-added renewable energy sources. Therefore, as discussed in this review paper, there are many positive indicators to support electric mobility in India and certainly, there will be considerable increase in the number of electric vehicles on Indian roads in the next five years.

Keywords: electric mobility; Indian strengths; electric vehicle targets; charging infrastructure; charging power demand; green energy for charging.

Classification: FOR Code: 290901

Language: English



LJP Copyright ID: 392993

Print ISSN: 2631-8474

Online ISSN: 2631-8482

London Journal of Engineering Research

Volume 20 | Issue 2 | Compilation 1.0



© 2020. Satyendra Nath Saxena. This is a research/review paper, distributed under the terms of the Creative Commons Attribution-Noncommercial 4.0 Unported License (<http://creativecommons.org/licenses/by-nc/4.0/>), permitting all noncommercial use, distribution, and reproduction in any medium, provided the original work is properly cited.

Strengths of India Related to E-Mobility

Satyendra Nath Saxena

ABSTRACT

India is importing a large percentage of petroleum products, and therefore in the interest of national energy security, it is essential for India to reduce the use of petrol and diesel-based vehicles and increase electrical vehicles on roads. Also, due to high levels of pollution in most of the Indian cities due to tail-pipe emissions from petrol and diesel vehicles, switching to electric mobility must be taken with increased efforts by the government and manufacturers. Supported by the policies of the government, there are great initiatives by many public sector and private organizations to gradually increase the number of charging stations for electric vehicles in cities and highways all over India. With availability of improved batteries, controllers and motors at lower costs in the coming 4-5 years, it is expected that the costs of all categories of EVs would come down to be competitive with the petrol and diesel-based vehicles. With ambitious plans of Indian Government to have power generation from renewable energy in the coming 10 years, the power demand for charging of electric vehicles can easily be met only from the newly-added renewable energy sources. Therefore, as discussed in this review paper, there are many positive indicators to support electric mobility in India and certainly, there will be considerable increase in the number of electric vehicles on Indian roads in the next five years.

Keywords: electric mobility; Indian strengths; electric vehicle targets; charging infrastructure; charging power demand; green energy for charging.

Author: NTPC School of Business, Noida, India.

I. INTRODUCTION

People require local transport for travel to office, educational institution, market, or for medical necessities and recreation. Due to financial constraints of State or Local Governments in India, the public transports (limited number of road transport buses or metro trains) are not in a position to satisfy the requirements of all people. This has led to the people, especially the salaried-class population, going for their personal vehicles (cars or two-wheeler vehicles), as they can easily afford these with availability of vehicle loans from the financial institutions. A large number of young people and ladies prefer to travel by two-wheeler scooters for reaching the destination without facing the crowded public transport.

Many people in India find it convenient to travel by cabs as these are available in a few minutes everywhere in cities due to many “App-based” cab operators, each introducing a large number of vehicles every month. Also, most of the public sector and private organizations are now not keeping cars for their staff and are hiring normal or luxury cars (depending upon the requirement on the coming day) from the “Travel Agents”; whose number is increasing every year in cities. Looking from another angle, the large number of cabs or cars with travel agents is providing self-employment to many people of all ages (having a driving license).

Similarly, there is considerable growth in the three-wheeler auto-rickshaws and three-wheeler electric-rickshaws in India due to the requirement of low-cost transport by the middle-class people. In all large cities, these three-wheelers are available as “pooled” vehicles, providing the

“first-mile” or “last-mile” connectivity to most of the office or college-going people at affordable rates. India is the largest manufacturer in the world of all types of three-wheeler vehicles. Again, these three-wheeler vehicles have also provided self-employment as drivers to millions of people in all major cities.

But, the large number of buses and personal or commercial vehicles on roads has resulted in problems of pollution in Indian cities. The Government of India (GoI) is trying to promote electric mobility (or green mobility) in India. For GoI, there are many compelling reasons for this objective.

1.1 National energy security

As the indigenous resources of petroleum are very less compared to the consumption, a large percentage of petroleum products are being imported, putting a heavy burden on the balance of payment situation for GoI. The quantity of imported petroleum products is increasing every year due to (a) the overall growth in Indian economy (US\$ 2.3 trillion as of November 2019, targeted to grow to US\$ 5 trillion by March 2025), (b) yearly increase in Indian population by about one per cent (1.38 billion in Jan 2020, expected to become 1.52 billion by 2030) and (c) a large number of rural people moving to cities in search of livelihood and better life (urban population of 31 per cent as per 2011 census, expected to become 42 per cent by 2030) [1]. But, the political situation in Middle-Eastern countries, from where the petroleum products are being imported, is a cause of concern (for example, gradual reduction in supplies from Iran). Therefore, from the consideration of national energy security, switching to e-mobility at the earliest has become an important matter, so that even with growth of economy and increase in urban population, the consumption of petrol and diesel in India will decrease gradually, reducing the import bill.

1.2 Pollution in cities

The pollution levels in almost all the large cities in India are much above the permissible values and have been deteriorating day-by-day. Apart from the exhaust from chimneys of fossil fuel based thermal power plants, the second major cause has been the tail-pipe emissions from the internal combustion engine (ICE)-driven vehicles on Indian roads. GoI [along with the Government of States / Union Territories (UTs)] is trying to introduce electric buses (in place of diesel buses) for public transport in the next 10 years. But, the major problem of pollution in large cities is due to personal vehicles (cars and two-wheelers). Therefore, if electric cars and two-wheelers of large varieties with modern features (similar to ICE-driven vehicles) are available in Indian cities from reputed manufacturers, then it is expected that the knowledgeable people in large cities will certainly purchase the EVs to help GoI in reducing the pollution.

But for the e-mobility to increase, the major hurdles cited by media reports are: (a) Limitation of EVs regarding distance covered with a fully-charged battery bank; (b) Lack of EV charging infrastructure in cities and highways; (c) Higher initial purchase price of EVs; and (d) Difficulty in meeting the charging power of large number of EVs in cities with growth in the number of vehicles by 2030. Each of these aspects is discussed in the next sections in order to inform the readers that many positive indicators exist in India and there are inherent strengths that will help in realizing the desired growth of EVs in India in the next 10 years.

II. DISTANCE LIMITATION OF ELECTRIC VEHICLES

During the last 2-3 years, a large variety of battery operated electric cars have been brought out in the market (and available even in India) by many reputed manufacturers, with most of these cars able to travel more than 300 km with a fully-charged battery bank. Some of these cars are given below, mentioning the “Car Model” along

with the maximum distance that can be covered with a fully-charge battery bank and the capacity of battery bank:

<u>Car Model</u>	<u>Max Distance</u>	<u>Battery Capacity</u>
• Nissan Leaf E+,	360 km,	60 kWh
• Jaguar I-Pace,	370 km	90 kWh
• Chevrolet Bolt,	380 km,	60 kWh
• Audi E-Tron,	400 km,	95 kWh
• Hyundai Kona,	452 km,	64 kWh
• Tesla Model-X,	470 km,	100 kWh
• Tesla Model-3,	500 km,	70 kWh
• Tesla Model-S,	530 km,	100 kWh

Many more car manufacturers (including a few Indian producers) are coming out with car models giving more than 300 km. Thus, there appears to be no limitation regarding the distance covered by the modern battery operated EV for daily travel in large cities and even for inter-city travel. (It must be mentioned that these distances mentioned are under test conditions and would get reduced when travelling with many persons, or with heavy luggage, or on an uphill terrain, or at high speed etc.)

But, regarding the personal cars, the average distance travel of office-going people is less than 100 km. Therefore, such people can go for cars with smaller battery capacity, which would have lower initial cost even with all the other modern features.

III. EV CHARGING INFRASTRUCTURE IN CITIES AND HIGHWAYS

As of now, there are very few EV charging stations in the major cities and hardly any on highways in India. In June 2018, there were about 150 EV charging stations in India. Up to Dec 2019, the number of charging stations was about 500 spanning major metropolitan cities like Delhi, Mumbai, Bengaluru, and Kolkata. But, the following are many positive developments which would certainly result in a large number of EV charging stations in the next five years.

3.1 Announcement of policies by GoI related to charging infrastructure

GoI has made the following announcements related to policies for EVs and charging stations [2].

At least one charging station should be available in cities in a grid of 3 km x 3 km.

- One charging station should be set up at every 25 km on both sides of highways.
- For long-range EVs (like long range SUVs) and heavy-duty EVs (like buses / trucks etc), there should be at least one fast charging station with adequate charging infrastructure at every 100km, one on each side of the highways / road, located preferably within / alongside the EV charging stations mentioned above (that is one every 25 km on highways).
- The charging installations are to be done in two phases; Phase-I (1 – 3 years) and Phase-II (3 – 5 years). In Phase-I, all mega cities with a population of more than 4 million (as per 2011 Census) and all existing expressways connected to these mega cities and important highways connected to each of these mega cities will be taken for coverage. These mega cities are: (1) Mumbai, (2) Delhi, (3) Bengaluru, (4) Hyderabad, (5) Ahmedabad, (6) Chennai, (7) Kolkata, (8) Surat and (9) Pune. The expressways and highways are: (1) Mumbai-Pune Expressway, (2) Ahmedabad-Vadodara Expressway, (3) Delhi- Agra Yamuna Expressway, (4) Delhi- Jaipur, (5) Bengaluru-Mysuru, (6) Bengaluru- Chennai, (7) Surat-Mumbai Expressway, (8) Agra- Lucknow Expressway, (9) Eastern Peripheral Expressway, (10) Delhi-Agra NH2 Expressway, (11) Hyderabad ORR Expressway, and 5 other connected Highways to each mega city. In Phase-II, big cities, like State Capitals and headquarters of Union Territories (UT) will be covered. Further, important highways connected with each of these cities will be taken up for coverage. Government has also notified the type of chargers to be installed at the charging stations.

3.2 Faster adoption & manufacturing of (hybrid &) electric vehicles

“Faster Adoption & Manufacturing of (Hybrid &) Electric Vehicles” (FAME-1) scheme was launched in April 2015 by the Ministry of Heavy Industries and Public Enterprises (GoI) for a period of 3 years; but was extended up to March 2019. Then FAME-2 was launched in April 2019, which has an outlay of Rs.100 billion for three years; Rs.15 billion during 2019-20; Rs.50 billion during 2020-21; and Rs.35 billion during 2021-22. Out of this, GoI has earmarked Rs.10 billion in the next three years for setting up 2700 EV charging stations including a sufficient number on major highways [3]. Government has already awarded contracts to the public sector organizations (NTPC, Power Grid Corporation, Rajasthan Electronics & Instrumentation Ltd, Energy Efficiency Services Ltd etc) for setting up 2600 EV charging stations in 62 cities with a million plus population. In addition, with the support of the Central Government, many State Governments have also announced policies for setting up of charging infrastructures in the cities in the respective States. The Central Government has also asked the concerned State / UT Governments to make the lands available for the EV charging stations and to inform the distribution companies (DISCOMs) to make the adequate supply / distribution network available as per the criteria / distances. The appropriate Central / State / UT Governments must give priority to the existing retail outlets of oil marketing companies for the installation of public charging stations.

3.3 Initiatives by many public sector and private organizations

Significant investment is being made by the private sector to manufacture and install EV infrastructure across India. This includes charging and battery swapping technologies. Plans are underway to fuel EVs with clean power, with industry players exploring solar-plus-EV technology in Mumbai and the other major cities. Moreover, the Indian Railways has announced its intention to allocate space for EV charging

stations at their station parking lots. Indian Railways authorities aim to invite private sector participation by issuing tenders to create this infrastructure. Public sector units in India have signed several Memorandums of Understanding (MoUs) with DISCOMs to develop dedicated EV charging stations across Indian cities. Many public sector organizations, including NTPC, Power Grid, Tata Power, Delhi Metro Rail Corporation (DMRC) etc and many travel companies have started installing EV charging stations and also planned to go in a big way in many cities. For example in August 2019, Indian Oil Corporation (in collaboration with NTPC) has opened its first EV charging station (with facility for charging up to four electric vehicles) in Greater Noida (UP) and plans to install many EV charging stations over the coming years across cities and highways [4]. Tata Power has set up more than 100 EV charging stations in India and number will be 300 by March 2020 and to more than 700 by March 2021, in order to provide charging stations in cities where a large number of e-cars exist [5].

In February 2020, Energy Efficiency Services Ltd (EESL) signed an MoU with Bharat Sanchar Nigam Ltd (BSNL) for setting up 1000 public EV charging stations in the premises of BSNL sites across the country in a phased manner [6]. BSNL would be responsible for providing the requisite space and power connections for installing the charging infrastructure. EESL will make the entire upfront investment on the services pertaining to the MoU, along with the operation and maintenance of the charging infrastructure by using qualified personnel. EESL has already commissioned 300 AC and 170 DC chargers across India, including 66 public charging points operational in Delhi National Capital Region (Delhi NCR).

In January 2020, a MoU was signed between Ashok Leyland and ABB Power Products & Systems to develop e-buses using the latest flash charge technology called as “Trolley bus Optimization System Alimentation” (TOSA) of ABB [7]. “TOSA” Is the fastest flash-charging

connection technology that does the topping (charging) of a battery bank of e-buses in seconds even as passengers get on and get off the bus. Besides, it reduces the environmental pollution of the transit systems without affecting passenger capacity or the journey time. When connected to charging infrastructure, the battery bank can be charged with a 600 kW power boost in 15 s. An additional few minutes of charge at the final terminal would result in full charge of the battery bank without interrupting the bus schedule.

In a major push to curb pollution, Gensol Mobility, a part of the Gensol Group, has launched India's first 100 per cent smart electric fleet of 70 cabs “Blu-Smart” in Delhi National Capital Region (Delhi NCR) in January 2019 based on e-Verito of Mahindra & Mahindra [8]. The company has invested Rs.500 million as its capital expenditure, and it has planned to set up a massive charging infrastructure comprising 65 stations. Each station will have the capacity to charge up to 20 vehicles at a time, with 20 charging points. The company has also ensured that there will be a charging station within every five km of radius.

GoI has announced a scheme to supply e-buses to many State Road Transport Undertakings (SRTC) with subsidized rates. Many State Governments have submitted their proposals and e-buses have already been introduced in many SRTC. The suppliers of these e-buses have come forward to install charging stations at the e-bus depots to which these buses are being supplied. Also, Ashok Leyland has already provided facility of swapping of battery banks at the e-bus depots in Gujarat.

From the above, it can be expected that there will be a large number of EV charging stations in all cities and highways throughout India in the next 5 years; and the bus depots and people can think of buying the EVs to save the running and maintenance charges.

IV. COST OF ELECTRIC VEHICLES

Presently, as compared to its corresponding vehicle based on ICE, the initial purchase price of every type of EV is higher; for which, there are incentives being offered by the Central and State Governments. But, one must consider the “Total Cost” of EV for comparing that with the “Total Cost” of ICE-based vehicles. The ICE-based vehicle has a large number of parts and requires frequent maintenance and replacements of parts, engine oil etc; on the other hand, EV has much lower maintenance cost. The running or operational cost for an EV is only for the energy required for re-charging (or top-up) of its battery bank; which is very small as compared to the monthly fuel cost for the ICE-based vehicle. With the regular increase in price of petrol or diesel, the operating cost of EVs would become lower in the coming years. Further, one must consider the costs related to health of citizens requiring control of pollution, noise etc. Taking it further, there are costs incurred by Indian Government to fight against climate change.

Due to development in technology and large scale production of lithium-ion batteries in many countries and with growth of EVs all over the world, the prices of higher density compact lithium-ion batteries are coming down. Battery prices, which were above US\$1,100/kWh in 2010, have fallen by 87 per cent to US\$156/kWh in 2019. By 2023, average prices will be close to US\$100/kWh, according to the latest forecast from BloombergNEF [9]. As the cost of battery bank constitutes about 30-40 per cent of the initial cost of EVs, It can be expected that the initial purchase prices of EVs would also come down. Further, considerable advances are taking place in power electronics and digital electronics, giving more powerful EV controllers at lower costs. Even more compact and powerful motors have been developed with reasonable cost. Therefore, it can be expected that the initial purchase price of EVs would become competitive in the coming 3-4 years.

V. ELECTRICAL POWER REQUIRED FOR CHARGING OF LARGE NUMBER OF EVS

Different media reports and announcements by various Ministries in Indian Government bring out different percentage implementation of e-mobility and varying dates of achieving the targets for each category of EV. The author has taken the reports of NITI Aayog [2, 3] for estimating the number of EVs of different categories by 2030 and for analysis of charging power required for those EVs by 2030. According to those reports, the following are some of the relevant points.

- Government would like to reach EV sales penetration of 30 per cent for private cars, 70 per cent for commercial cars, 40 per cent for buses, and 80 per cent for two-wheelers and three-wheelers by 2030.
- From April 2030, only electric buses and electric cars will be registered.
- From April 2026, only e-cabs will be registered.

It is often mentioned in the media reports that the charging of electric vehicles (EVs) consumes considerable power; and with growth of EVs as per targets of GoI, it would be difficult for electric grid in India to manage the supply for this purpose. The author has tried to analyze the matter to know the real issue.

5.1 Three-wheeler electric-rickshaws

A few years ago, manual-driven three-wheeler rickshaws were being used all over India for movement of people for short distances and for providing “first-mile” and “last-mile” connectivity to people for travelling to nearby markets, bus stands or metro stations. The battery-powered three-wheeler rickshaws (e-rickshaws) were introduced in Delhi during the Commonwealth Games in 2010. But, these gained popularity in India since 2015. Almost 300,000 battery powered rickshaws have now replaced the cycle rickshaws in key markets of the North East, Uttar Pradesh, West Bengal, Delhi and Bihar States of India [10]. These e-rickshaws have become one of

the fastest growing segments in India, with a compounded growth rate of 20 per cent in the past four years. The main reasons for this fast growth of e-rickshaws in India have been preference by the middle-class people to make use of this low-rental mode of transport for short distances and opportunity of providing self-owned jobs for people of all ages and even for people with no formal education.

Electric-rickshaw sales were 400,000 units in 2015-16. There is no officially known figure regarding the total number of e-rickshaws in India, because these do not require registration in many states. For analysis of power requirement of e-rickshaws, the “Handbook : E-Rickshaw Deployment in Indian Cities, 2019” has been considered, which mentions the number of e-rickshaws to be about 1.5 million in March 2018 [11]. Assuming a yearly growth rate of 20 per cent from 2018 to 2030, the number of e-rickshaws is estimated to be about 13 million by March 2030.

There are three categories existing in India regarding ownership and charging of e-rickshaws.

- There are some owners of EVs who have their own houses and have facilities for parking and charging of EVs. These EVs are charged by the owners during night time.
- There are some EV owners who live in small rented houses and do not have the facilities of parking or charging of EVs. These drivers are also afraid to keep the EVs on the road due to chances of theft of EV parts. Finding the opportunity, some “Garages” have been set up, who provide the parking and charging facilities to these EVs at night for some monthly charges.
- As most of the EV drivers have migrated from small villages to large cities in search of livelihood, they have poor economic conditions and are not able to purchase the EVs. In the absence of any property to provide surety, they are not able to get loans from the financial institutions. This situation has given rise to “Agents”, who purchase the EVs in bulk directly from the manufacturers and give on daily or monthly rent to the drivers. The drivers will

return the EVs at night to the agents' parking places, where charging of EVs would be done at night.

A report by Institute of Urban Transport [12] mentions that, on an average in Indian cities, the first two of the above categories constitute about 50 per cent and the third category makes the remaining 50 per cent. But in all the situations, the charging of e-rickshaws is being done at night. "Trio" e-rickshaw of the Indian manufacturer (Mahindra & Mahindra) has been taken here for computation of charging power [13]. This EV has 3.69 kWh of lithium-ion battery bank, required to be charged in 2 hours 30 minutes (2.5 hours). It is assumed that the battery bank is required to be charged by 50 per cent every night.

Charging energy = $0.5 \times (3.69 \text{ kWh}) = 1.845 \text{ kWh}$ in 2.5 hours

Power demand of each e-rickshaw = $(1.845 \text{ kWh}) \div (2.5 \text{ hours}) = 0.738 \text{ kW}$

All the e-rickshaws would be put for charging after the driver comes back to home or gives it back to the owner. For this computation, a factor of 30 per cent (out of 13 million e-rickshaws by 2030) is assumed to be charged simultaneously on Indian grid as there are many hours available for charging in the night.

Therefore, power demand on Indian grid = $(0.738 \text{ kW}) \times (0.3 \times 17,000,000)$

$= 3,763,800 \text{ kW} = 3,764 \text{ MW} = 3.764 \text{ GW}$.

As this demand for e-rickshaws is distributed in a large number of cities, towns and even small places, this would not pose problem for the Indian National Grid (having total installed power capacity in Jan 2020 of about 368 GW, which is expected to become 832 GW by 2030) or for cities and that too in the night time when the other loads are very small.

5.2 Two-wheeler EVs

As per the data for two-wheelers released by CEIC, there were about 187,091 two-wheelers in

India in March 2017 [14]. For the purpose of computation of charging load on National Grid, it is assumed that the total number of e-scooters in India in 2030 would be about 8 million. Also, it is taken that the average capacity of the lithium-ion battery pack in each scooter would be about 3 kWh, which when fully charged is sufficient for the running of an e-scooter for the full one day. The employees in the government / public sector / private sector having facilities of charging (taken about 25 per cent of the total electric two-wheelers) can do the charging in the office complex in 2 hours during day time; and the remaining 75 per cent battery bank of electric two-wheelers can be charged in 2 hours during night time at their residences.

With 50 per cent top-up required during each charging, the energy required will be
 $= 0.5 \times (3 \text{ kWh}) = 1.5 \text{ kWh}$

When charged in 2 hours, the power demand of each e-scooter = $(1.5 \text{ kWh}) \div (2 \text{ hours}) = 0.75 \text{ kW}$.
 For 25 per cent of the total e-scooters charged during day time in offices:

Power demand = $(0.75 \text{ kW}) \times (0.25 \times 8,000,000)$
 $= 1,500,000 \text{ kW} = 1,500 \text{ MW} = 1.5 \text{ GW}$

For 75 per cent of the total e-scooters (8 million) charged during night time at residences:

Power demand = $(0.75 \text{ kW}) \times (0.75 \times 8,000,000)$
 $= 4,500,000 \text{ kW} = 4,500 \text{ MW} = 4.5 \text{ GW}$

The above power demand would be distributed all over India (because two-wheelers are being used even in small places apart from towns, cities and metros). Therefore, the power demand of this magnitude may not be of any problem in 2030 for the National Grid and also in cities or small towns of India both during day time and night hours.

5.3 Electric buses

Although GoI has set a target of 40 per cent e-buses by 2030, it appears to be difficult because there would be 0.2 million buses with State Road Transport Corporations (SRTCs) and 7.8 million buses with private operators by 2030 [15]. As the e-buses are costlier as compared to the diesel or gas operated buses, the private operators would

not be able to invest the required huge amount every year to procure the e-buses (even considering the incentives being offered by GoI). Therefore in this paper, it is assumed that GoI will be able to have 40 per cent of EVs (that is 0.08 million) in the fleet of SRTCs by 2030. But for the computation of EV charging load in 2030 on Indian National Grid for the private bus operators, four cases have been considered. It is taken that the number of e-buses in the total fleet by 2030 could be:

Case-A 10 per cent (0.78 million);
Case-B 20 per cent (1.56 million);
Case-C 30 per cent (2.34 million); and
Case-D 40 per cent (3.12 million).

Combining these figures of private e-buses with those with SRTCs (0.08 million), the total number of buses to be charged is expected to become: 0.86 million, 1.64 million, 2.42 million, and 3.20 million for Cases A, B, C and D, respectively.

Assuming that on an average, the e-bus battery capacity is 300 kWh and that each bus requires charging (top-up) of 50 per cent, which would demand $(300 \text{ kWh}) \times 0.5 = 150 \text{ kWh}$.

As the number of buses for most of the operators (including SRTCs) is small, each bus would require fast charging (top up) in one hour during day time, so that the e-bus could go back again for the next trip. Thus, charging of each bus during day time demands a power of $(150 \text{ kWh}) \div (1 \text{ hr}) = 150 \text{ kW}$.

Assuming that 10 per cent of the e-buses in India get charged simultaneously, the total number of e-buses to be charged simultaneously on Indian grid would be 86,000 for Case-A; 164,000 for Case-B; 242,000 for Case-C; and 320,000 for Case-D. Therefore, the total charging load on National Grid would be as given below.

Case-A: Total load = $86,000 \times (150 \text{ kW}) = 12,900,000 \text{ kW} = 12,900 \text{ MW} = 12.9 \text{ GW}$
Case-B: Total load = $164,000 \times (150 \text{ kW}) = 24,600,000 \text{ kW} = 24,600 \text{ MW} = 24.6 \text{ GW}$

Case-C: Total load = $242,000 \times (150 \text{ kW}) = 36,300,000 \text{ kW} = 36,300 \text{ MW} = 36.3 \text{ GW}$

Case-D: Total load = $320,000 \times (150 \text{ kW}) = 48,000,000 \text{ kW} = 48,000 \text{ MW} = 48.0 \text{ GW}$

For the installed power capacity of 832 GW by 2030, this demand of about 13 GW, 25 GW, 36 GW or 48 GW for the four computed cases may not be of any concern. But, as most of these e-buses will be concentrated in 10 metro cities, each metro city has to provide for the additional EV charging power load of: about 1.3 GW, 2.5 GW, 3.6 GW or 4.8 GW for the four cases. This power demand for metro cities during day time is certainly quite substantial and requires proper planning by the city administrations along with the DISCOMs. Of course, as the number of e-buses in the different cities would not be the same, there would be variations in the power demands in the different metro cities from the GW values calculated. Therefore, DISCOM of each city must estimate the number of e-buses to be charged for the next 5 years and 10 years and plan in advance regarding cabling of 11 kV or 33 kV networks to set-up the substations at the different e-bus depots and plan to supply the required electric power as and when these come up.

5.4 Personal electric cars

Due to public transport being not so convenient, and with availability of large number of models of cars from reputed manufacturers and with easy availability of loans for salaried people, there has been an explosive growth in the number of private vehicles on the Indian roads, giving the problems of traffic congestion on roads and air pollution due to the tail-pipe emission of gases from these petrol/diesel-driven cars, leading to several diseases in the people of all age groups.

The total number of cars in India was about 10 million in 2016 [16]; and with assumed linear growth rate of 10 per cent per year, it can be said that the number of cars on Indian roads would be more than 37 million by 2030.

In order to have more than 30 per cent e-cars on Indian roads by 2030, the total number of e-cars is required to be more than 11 million. But, with the high cost of electric cars in India compared to the mass-produced petrol / diesel-engine cars, the number of electric cars sold in India [17] has been just 1,200 in 2017-18 and 3,600 in 2018-19. In India, it is a typical “hen and egg” situation; there is low demand of EVs because the production is low and there are very few charging infrastructures; and the manufacturers are not coming forward because there is low demand. With such low volume sales of electric cars, reaching a target of 11 million e-cars in the next 10 years looks really challenging for the Indian Government. Therefore, for computing the load demand of charging infrastructure for e-cars on National Grid in 2030, here also three cases are considered;

Case-AA where e-cars could be 10 per cent = 3.7 million;

Case-BB where e-cars could be 20 per cent = 7.4 million; and

Case-CC where e-cars could be 30 per cent = 11.1 million.

It is expected that by 2030, a good number of government / public-sector / private-sector organizations will be providing charging points in the office complexes to encourage the employees to purchase and come to offices by e-cars; and so it is taken that about 25 per cent of the total e-cars are charged in the offices with fast charging in one hour during day time. Fast charging is desirable, so that more number of employees can use the limited charging facilities. The remaining 75 per cent of the e-cars (belonging to the shopkeepers, or for the staff of offices not providing charging points) will be charged in the houses in 3 hours during night time.

It is assumed that most of the cars would have a lithium-ion battery bank with an average capacity of 50kWh. With 50 per cent of top-up for the 50 kWh battery bank, the charging for each e-car will consume = $0.5 \times (50 \text{ kWh}) = 25 \text{ kWh}$.

5.4.1 Twenty five per cent charging of personal e-cars in offices during day time

For day time charging in offices in one hour for 25 per cent of e-cars, the power demand on the National Grid will be as given below. Power required = $(25 \text{ kWh}) \div (\text{one hour}) = 25 \text{ kW}$

Case-AA: $(25 \text{ kW}) \times (0.25 \times 3,700,000) = 23,125,000 \text{ kW} = 23,125 \text{ MW} = 23.125 \text{ GW}$

Case-BB: $(25 \text{ kW}) \times (0.25 \times 7,400,000) = 46,250,000 \text{ kW} = 46,250 \text{ MW} = 46.250 \text{ GW}$

Case-CC: $(25 \text{ kW}) \times (0.25 \times 11,100,000) = 69,375,000 \text{ kW} = 69,375 \text{ MW} = 69.375 \text{ GW}$

Assuming that the above power demand is distributed in 10 major cities, the power demand in each city would be about 2 to 7 GW. This should be added to the power demanded in day time by the e-buses, computed in Section 5.3. The total power demand comes out quite substantial and requires serious considerations by DISCOMS of respective cities to plan in advance the distribution systems.

5.4.2 Seventh five per cent charging of personal e-cars in residences during night time

For night time charging, the percentage of e-cars being charged simultaneously would be small as the car owners may get the charging done for 2 to 3 hours any time from 20.00 hrs to 06.00 hrs. Also with small distances travelled by the personnel cars, the battery bank of cars would not get discharged much and the cars can be charged even after one or two days. Further, the loads in cities during night time are small and additional loads of e-car charging would not be of much problem.

5.5 Electric cabs

There were about 2.5 million cabs in India in 2016 [18]. Here pessimistically, a yearly growth rate of 10 per cent has been assumed for the next 14 years, to give 9.5 million by 2030. With 70 percent of cabs to become electric, the number of ecabs is expected to be about 6.6 million by 2030.

The e-cabs have longer running distance every day and would certainly require charging of the battery bank two or three times during day time at the public EV charging stations in cities. Taking that each e-cab has a battery bank of average of 50 kWh, to get top-up by 50 per cent in 30 minutes (1/2 hr); Power = $(0.5 \times 50 \text{ kWh}) / (0.5) = 50 \text{ kW}$. If it is assumed that about 10 percent of e-cabs are getting charged simultaneously, total charging power for $0.1 \times 6,600,000$ e-cabs
 $= 0.1 \times 6,600,000 \times 50 \text{ kW} = 33,000,000 \text{ kW} = 33,000 \text{ MW} = 33 \text{ GW}$.

This amount of power required in 2030 would not be any problem for the Indian Grid of 700 – 800 GW. But, as the e-cabs are concentrated mainly in a few large cities (say 10 cities), the charging load of 3.3 GW in a city in day time along with the charging load of e-buses (computed in Section 5.3) and of personal e-cars (computed in Section 5.4.1) requires proper thinking by the DISCOM of that city.

Apart from the above, there is an alternative way of computation of charging power for a large city. As mentioned above, GoI has desired EV charging stations in all large / major / metro cities in a grid of 3 km x 3 km. In metro cities, this involves a large number of commercial EV charging stations. For example, taking the case of Delhi NCR (which has some areas of Haryana and U.P. along with Delhi city), the power required in 2030 will be as calculated below.

- Delhi NCR has an area of 55,000 sq km. There must be one charging station in an area of 3 km x 3 km = 9 km². So, the number of charging stations = $(55000/9) = 6111$.
- Taking that each car has battery bank of average of 50 kWh, to get top-up by 50 per cent in 30 minutes (1/2 hr); Power = $(0.5 \times 50 \text{ kWh}) / (0.5) = 50 \text{ kW}$
- If there are 10 charging points in each charging station, then power required in Delhi NCR in day time = $10 \times 50 \text{ kW} \times 6111 = 3,055,500 \text{ kW} = 3,056 \text{ MW} = 3.1 \text{ GW}$, which works out to be nearly the same amount as computed above.

5.6 Analysis of power requirement for charging of EVs (computed in Sections 5.1 to 5.5)

It may be pointed out here that the purpose of computation of power required for charging of the different categories of EVs was done just to get an approximate idea about the range of power (and not the exact GW). The computations done above in Sections 5.1 to 5.5 have clearly shown that the total power required for charging of EVs by 2030 would not be any issue for the Indian grid. Fortunately, GoI has ambitious targets to have renewable energy (RE) generation, and most of the power demand can be met from the power produced by these RE generation. As on Jan 31, 2020, the installed capacity of renewable energy sources (RES) excluding large hydro was 85.908 GW, and large hydro was 45.399 GW. Thus, the total non-fossil based power capacity in India was 131.307 GW [19]. India has set a target of 175 GW of RES (excluding large hydro) and 51 GW of large hydro by 2022; the total becoming 226 GW, which is about 48 per cent of the total installed capacity of 478 GW by 2022. The total non-fossil based power capacity by 2030 is expected to be about 523 GW, which would be about 63 per cent of the total installed capacity of 832 GW in the country. Therefore, the increase of power required for the charging of EVs can easily be met by a much larger increase in RES.

Only point is that the DISCOM of each city must estimate the number of EVs in the next 5 years and 10 years in its area of operation, and compute the approximate amount of power required at different e-bus depots, various public EV charging stations, and at different residential complexes for planning the laying of 11 kV or 33 kV cables in the distribution system. This would ensure that the DISCOM is well prepared to set-up the substation and provide the power required whenever an e-bus depot or public charging station comes up.

5.7 Convenience of battery swapping provided by suppliers

The showrooms of major car manufacturers (such as, Maruti, Hyundai, Mahindra & Mahindra, Tata

Motors etc) can also have the business of “Battery Swapping” at their service stations. Since the number of battery variants is known to these authorized service stations for their cars, they can keep a few number of those battery banks fully charged. When a personal car or cab owner comes to the service centre, their staff can replace the partially-discharged battery bank with a fully-charged battery bank in a few minutes. Swapping the battery bank gives the advantage to the EV owner of saving in time as the swapping can be completed in a few minutes compared to a minimum of one hour even with fast charging. With swapping, the driver does not have to worry about battery warranty, battery life, battery maintenance etc.

As all the buses in an electric bus depot will be from one supplier, the bus depot can purchase about 20-25 per cent spare batteries at the time of purchase of buses and keep those charged. When a bus comes back to depot after a trip, the electrical staff can quickly remove the partially-discharged battery bank and put a fully-charged battery bank in the bus. Thus, the bus will be able to go for the next trip with a stopover of only a few minutes. The partially discharged battery bank can be charged by the electrical staff of the bus depot conveniently with a slow charger.

However, it would not be a profitable business for individuals to start a battery swapping station; which involves high investment required to develop the infrastructure for charging of the discharged batteries received from the customers. To have capability of charging a few number of high kWh batteries, this involves setting up of a high voltage (11 kV) substation along with a transformer, circuit breaker and the other protection equipment. Also, the swap station has to store a few numbers of different types of batteries as required by the customer. This involves expenditure of procuring and storing large varieties of batteries of different capacity and from different suppliers. Due to all these difficulties, battery swapping may not be available commercially as “Swap Stations” except at the

showroom or service stations of the car manufacturers.

VI. OTHER STRENGTHS IN INDIA

Apart from the positive development in India as discussed above, there are other favorable aspects existing, which would help in faster growth of EVs in Indian market.

6.1 Large public and private sector organizations (manufacturing electrical machines, power electronics equipment, batteries etc)

Immediately after independence, India had established a number of Public Sector Undertakings (PSUs), which have built modern India, which we see today. Bharat Heavy Electricals Ltd (BHEL) has supplied electrical machines, transformers, power electronics equipment etc for most of the power stations and industries. NTPC Ltd has been responsible for setting up most of the large coal-based thermal power plants in India up to 800 MW generator capacities. Power Grid Corporation of India Ltd (PGCIL) has established millions of circuit km of EHV AC, HV AC, HVDC transmission systems and substations of millions of kVA. There are many other public sector and private sector manufacturing organizations in India with established production bases to supply all the equipment required for EVs and also financially strong to set up the EV charging stations all over India as has been mentioned in Section-3.

India also has many reputed companies manufacturing lead acid batteries for decades. With ambitious GoI plans related to EVs deployment on Indian roads, manufacturers are coming forward to produce lithium-ion battery banks in India. Most of these suppliers are importing the lithium-ion cells and assembling battery units in India. But now, GoI has made plans to support setting up of a few large-scale, export-competitive integrated batteries and cell-manufacturing giga-plants in India and to

localize production across the entire EV value chain. The government is in the process of opening tenders to set up a 50 GWh battery manufacturing base with investment of around US\$ 50 billion. To support this, the government is offering financial incentives in the form of subsidies and duty cuts, which could include a reduction in minimum alternate tax to half and import and export duty waivers or cuts for eight years. The successful bidder companies must set up production facilities by 2022 and can apply incentives until 2030. The State Governments (where the plant will be set up) must facilitate land acquisition, single-window clearance and environmental clearance. The above mentioned government's initiative is intended to improve value adding and capacity building to allow India to be self-reliant in achieving its targeted per cent of its road vehicles being electric by 2030. Over a dozen companies ranging from national and international auto component manufacturers to power and energy solutions providers have rolled out their plans to make lithium-ion batteries locally to cash in on the wave for green vehicles in the country. The list includes Exide, Exicom, Amaron, Greenfuel Energy Solutions, Trontek, Coslight India, Napino Auto & Electronics, Amara Raja Batteries, Trinity Energy Systems, Versatile Auto Components, etc.

Many of the above mentioned and other organizations are setting up EV charging stations all over India. Large oil companies have many thousands of petrol / diesel filling stations and have now come up to install EV charging stations in cities and highways.

6.2 Various favorable policies by GoI related to electric mobility

FAME-I and FAME-II, and many other policies of various Ministries of GoI have been announced to encourage e-mobility in India. Some of these are as given below [2, 3].

- In 2010, Ministry of New and Renewable Energy (MNRE) proposed a 20 per cent capital subsidy for EVs that resulted in a big uptake, mostly in the e-bikes segment.
- Under the FAME-I scheme, there were subsidies up to Rs.29,000 for e-bikes and up to Rs.138,000 for every e-car sold. In the three wheeler EV segment, the governmental incentives ranged from Rs.3,300 to 61,000; while in electric LCVs, the same was from Rs.17,000 to 187,000 for every vehicle.
- Under FAME-II, incentives were provided for the purchase of 7,090 electric buses with an outlay of Rs.35.45 billion; 35,000 four-wheelers with Rs.5.25 billion; and 500,000 three-wheelers with Rs.25 billion. The centre plans to roll out an incentive of Rs.10,000 per kW for two-, three- and four-wheelers, based on the size of their batteries.
- Ministry of Power issued a clarification stating that charging of EVs is considered a service, not a sale of electricity, meaning that no license is required to operate EV charging stations.
- Ministry of Road Transport and Highways announced that battery-operated vehicles, both private and commercial, will be given green license plates; all battery-operated transport vehicles will be exempted from the requirement of permits; and amended Central Motor Vehicles Rules 1989 to allow driving licenses to be given for age group 16 to 18 years to drive gearless electric scooters and bikes up to 4 kWh battery size.
- Ministry of Finance has rationalized the customs duty for all categories of vehicles, battery packs and cells to support "Make in India" and incentivize uptake of EVs.
- GoI has approved the National Mission on Transformative Mobility and Battery Storage, which will drive clean, connected, shared, sustainable and holistic mobility initiatives. The Mission aims at creation of a Phased Manufacturing Program for five years, to support setting up of large-scale, export-competitive integrated batteries and cell-manufacturing giga-level plants in India, as well as localizing production across the entire electric vehicle value chain.
- In Aug 2019, Centre sanctioned 5595 electric buses for 64 cities under Rs.100 billion FAME-II Scheme. Gujarat will get 550 electric

buses for 5 cities, with Ahmedabad getting 300 buses. Maharashtra will get 725 electric buses for 6 cities. Uttar Pradesh will get 600 electric buses for 11 cities. 300 buses will be given to each of the other cities (Delhi, Bengaluru and Hyderabad). The subsidy will be at least 40 per cent of the e-bus cost. The cities can choose the type of buses depending upon their needs. The buses are in 3 categories: “Standard” (10 – 12 m length); “Midi” (8 – 10 m length); and “Mini” (6 – 8 m length).

- In order to enhance clean mobility in the road transport sector, in Jan 2020, the Department of Heavy Industries has sanctioned 2,636 charging stations for 62 cities in 24 states under FAME-2. The proposals were submitted by 19 public entities. Of these 2,636 charging stations, 1,633 will be fast-charging stations and 1,003 will be slow-charging. With this, the total number of charging stations planned to be installed across select cities in the coming three years has gone up to about 14,000.

6.3 Industry initiatives

According to market estimates, in the financial year 2018, electric two-wheeler sales almost doubled to 54,800 compared to the previous financial year. Electric two-wheelers have been leading the EV market; estimates suggest they account for 98 per cent of India's EV sales (not considering e-rickshaws) [20]. Established and new manufacturers are starting to invest in the Indian EV market through fund infusion, investments in start-ups and expansion plans. Companies are designing and testing products suitable for the Indian market with a key focus on electric two-wheelers and three-wheelers. OEMs have been forging partnerships with the State and City Governments, such as Delhi, Pune, Ahmedabad and Bengaluru, to augment the public transport system to promote shared mobility. In March 2019, over 100 companies showcased electric vehicles of all types at the India E-Vehicle Show. Similarly in India Auto Expo (at Greater Noida, UP) in February 2020, a large number of companies demonstrated EVs.

BYD makes electric buses locally, the K7 (a 9 meter long e Bus) and K9 (a 12 meter e-Bus), which are both capable of driving 250 km on a single charge. So far, BYD has more than 200 battery-powered electric buses running on road commercially in India. BYD plans to increase its output capacity for electric buses to 5,000 every year from 2,000 now. In India, BYD has partnered Hyderabad-based Olectra for manufacturing and supplying electric buses. Currently, the firm has orders for more than 200 units and is targeting to sell 10,000 units within the next 2 to 3 years. It has two factories covering more than 140,000 square meters, with a cumulative investment of almost US\$ 150 million.

6.4 Advantage India regarding small vehicles

The availability and utilization of small vehicles (such as, two-wheelers, three-wheelers, economy-size four wheelers and small three / four wheeler goods vehicles) is unique in India. These small vehicles require different sets of technologies and production capabilities. Therefore, India can develop small electric vehicles that can not only meet the domestic demand but can also be exported to many countries.

India is the largest manufacturer of all types of three-wheeler vehicles. The three-wheeler segment (mostly with ICE) has reported a robust 24 per cent growth in overall volume (sales) in 2018-2019, due to 49 per cent growth in exports. Total sales of three-wheelers during 2018-19 stood at 1.269 million units, against 1.017 million units in 2017-18 [21]. While the domestic sales during 2018-19 saw a 10 per cent growth to 701,011 units as compared to 635,698 units in 2017-18, exports supported domestic sales heavily with 49 per cent growth to 567,689 units in 2018-19, against 381,002 in the year-ago period, said the data from Society of Indian Automobile Manufacturers (SIAM). This could be possible primarily due to enormous demand for the low-cost Indian three-wheelers in Asian and African regions. Now, if India can develop low cost electric three-wheelers (both for passenger travel and goods transport), then India will be in a

unique position to export a large number of electric three-wheelers also to these countries.

Similarly, if Indian manufacturers can develop compact / economy size four-wheelers with all modern and advanced features, then these vehicles also will be a good product for the export, earning valuable foreign exchange.

VII. RECOMMENDATIONS FOR IMPROVEMENTS IN ELECTRIC MOBILITY IN INDIA

7.1 OEMs and dealers could collaborate to increase customer awareness and access to EVs

Globally, a lack of variety in EV models has been linked to weak EV adoption because consumer preferences vary significantly. Further, auto-dealers are often poorly trained to sell EVs or may even discourage sales of EVs in favor of ICE vehicles as the latter are linked to higher maintenance and spare parts revenues.

Therefore, it is necessary to educate salespersons and dealerships on the merits of EVs vis-à-vis ICE vehicles. Also, dealers must showcase EVs prominently at showrooms and ensure that test-rides can be readily offered. Further, they must provide information to potential EV customers on where public charging infrastructure is available in their region. OEMs could provide higher sales-linked incentives to dealerships and salespersons for sales of EVs relative to ICE vehicles. In addition, dealers may stock and sell vehicle-compatible EV charging infrastructure at the dealership to ease customer experience. Further, it would be preferable if the dealers could also keep charged battery banks in order to provide the battery swapping facility to the customers, especially for the e-cabs who would not like to wait during busy day time for charging of their EV battery banks.

For e-cabs and private bus operators, manufacturers should tie-up with financial institutions to provide loans at low interest rates with mini-

mum procedural hurdles, so that the owners find it convenient to purchase EVs to improve their business. For these categories of EVs, the daily running distances are more, giving higher benefits due to lower operating and maintenance cost; so that even with higher present day initial purchase cost, the pay-back period is very short. Government must take initiative to provide funds to financial institutions at low interest rates for financing these commercial EVs. Most e-rickshaws are purchased by “Middle Men”, who give these to poor e-rickshaw drivers on rent. State Governments must come forward to help these drivers in providing loans at very low interest rates for purchase of e-rickshaws and low-income group houses with charging facilities, which would improve the living conditions of families of millions of e-rickshaw drivers.

Presently, there are a large number of “Home Delivery” companies, and more such delivery organizations are coming up every month. The reason for this growth could be that people are finding this “Home Delivery” model convenient, as they are able to check the prices of a large variety of products from different reputed manufacturers and select the best product with competitive prices. These organizations are employing young people (who can drive two-wheelers) for delivery of the food items or household goods to the thousands of homes in cities every day using petrol-driven motorbikes. These home delivery organizations must be incentivized to have electric two-wheelers to reduce the city pollution.

7.2 Government must support auto industries to change over to EVs

Looking from the side of auto industries, it must be accepted that today, these are all manufacturing ICE-based vehicles, employing about 30 million people (both directly and indirectly), and account for more than 7 per cent of India’s GDP. The change-over of production from ICE-based vehicles to EVs would require considerable capital expenditure. Therefore, GoI and Governments of States must provide support to these industries in

terms of financing and incentives for production of EVs, so that they can gradually reduce the production of ICE-based vehicles and start increasing the production of EVs, so as to meet the targets set by GoI for the different categories of EVs.

VIII. CONCLUSIONS

The paper has attempted to review the situation in India regarding the growth of e-mobility. Reducing the number of petrol and diesel-driven vehicles and increase in the electrical vehicles on roads have become essential for the Government of India from the considerations of “National Energy Security” and for reducing pollution in cities due to tailpipe emissions from the vehicles. Therefore, as discussed in this paper, the Government is trying to bring out a number of policies and provide support to the State Governments and manufacturers for increasing the number of electric vehicles and their charging stations in cities and on highways; for which, many public sector and private organizations are also supporting the efforts of the Government. Although the cost of electric vehicles is presently higher than petrol or diesel-based vehicles, the development in battery technologies and their increased production due to higher demand would certainly result in reduction in the cost of battery banks and corresponding lower cost of electric vehicles. The Government has ambitious plans to develop renewable energy in the coming 10 years; and therefore, the power demand of the electric vehicles as per the targeted growth can easily be met by the much higher installation of renewable energy plants all over India.

REFERENCES

1. Ministry of Finance, Government of India, “National Infrastructure Pipeline”, Dec 2019
2. NITI Aayog, “Zero Emission vehicles: Towards a Policy Framework”, Sept 2018.
3. NITI Aayog and Rocky Mountain Institute, “India’s Electric Mobility Transformation”, April 2019.
4. Live Mint (August 2019), “Greater Noida gets its first electric car charging station”, www.livemint.com (last accessed on Sept 23, 2019)
5. Live Mint (Feb 2020), “Tata Power plans to have 700 EV charging stations by 2021”, www.livemint.com (last accessed on Feb 20, 2020).
6. Business Standard: “EESL inks pact with BSNL for 1,000 EV charging stations across country”, Feb 18, 2020
7. ABB: ABB Power Grid and Ashok Leyland team up for Greener Electric Buses”, new.abb.com > news (last accessed on Feb 20, 2020).
8. NDTV: “India’s First All-Electric Cab Services “Blue Smart” Launched in Delhi NCR”, auto.ndtv.com (last accessed on Feb 20, 2020).
9. Bloomberg NEF (Dec 2019), “Battery Pack Prices Fall”.
10. Economic Times, 2019, “E-rickshaws show the way in tier II-III cities”, <https://m.economictime.com>
11. Shakti Foundation: “Handbook – E-Rickshaw Deployment in Indian Cities”, 2019.
12. Institute of Urban Transport, “Improving and Upgrading Electric Rickshaws in Indian Cities”, 2015.
13. M&M, www.mahindraelectric.com, 2019.
14. CEIC: “India, Registered Motor Vehicles: Two Wheelers”, www.ceicdata.com (last accessed on Jan 20, 2020).
15. OGD PMU Team: “Buses Owned by the Public Sector in India from 2001 to 2015”, <https://community.data.gov.in> (last accessed on Sept 13, 2019).
16. Maps of India, “Top Ten Towns with Highest Numbers of Car Ownership”, <https://www.mapsofindia.com> (last accessed on Sept 13, 2019).
17. Auto Car, “EV Sales in India Cross 750,000 Mark in 2018-19”, <https://www.autocarindia.com> (last accessed on Sept 11, 2019).

18. Statista, “Number of registered Taxis by States”, 2016, <https://www.statista.com>
19. CEA: “All India Installed Capacity (in MW) of Power Stations”, Feb 2020, [cea.nic.in>reports](http://cea.nic.in/reports)
20. Financial Express, 2019, “Autp sales on Track: 3-Wheelers Buck the Trend with 24 % Growth in FY19”, <http://www.financialexpress.com>



Scan to know paper details and
author's profile

Alternative to the Maxwell Equations

Prof. v. Etkin

Togliatti State University

ABSTRACT

Based on the law of conservation and transformation of energy in nonequilibrium multivariate systems, maxwell-like equations of the processes of mutual transformation of force fields are found that do not require any hypotheses and postulates and cover a wider range of phenomena. The equations do not contain field operators and are extremely simple. Their application allows us to overcome the limited nature of Maxwell's equations by closed currents and also fields of vector nature, and are free from a number of inherent contradictions. The tensor nature of magnetic fields and the ability of the moment of Lorentz forces to do work are proved. The meaning of the vector magnetic potential as a function of the speed of rotation of the charge is revealed and the presence of a divergent component of a scalar nature is revealed. The necessity of taking into account the convective components of the bias currents is shown, and the applicability of maxwell-like equations to gravitational fields is substantiated.

Keywords: maxwell equations, electricity and magnetism, potentials and charges, forces and moments, interconversion of fields.

Classification: FOR Code: 010599

Language: English



LJP Copyright ID: 392994

Print ISSN: 2631-8474

Online ISSN: 2631-8482

London Journal of Engineering Research

Volume 20 | Issue 2 | Compilation 1.0



© 2020. Prof. v. Etkin. This is a research/review paper, distributed under the terms of the Creative Commons Attribution-Noncommercial 4.0 Unported License <http://creativecommons.org/licenses/by-nc/4.0/>, permitting all noncommercial use, distribution, and reproduction in any medium, provided the original work is properly cited.

Alternative to the Maxwell Equations

Prof. V. Etkin

ABSTRACT

Based on the law of conservation and transformation of energy in nonequilibrium multivariate systems, maxwell-like equations of the processes of mutual transformation of force fields are found that do not require any hypotheses and postulates and cover a wider range of phenomena. The equations do not contain field operators and are extremely simple. Their application allows us to overcome the limited nature of Maxwell's equations by closed currents and also fields of vector nature, and are free from a number of inherent contradictions. The tensor nature of magnetic fields and the ability of the moment of Lorentz forces to do work are proved. The meaning of the vector magnetic potential as a function of the speed of rotation of the charge is revealed and the presence of a divergent component of a scalar nature is revealed. The necessity of taking into account the convective components of the bias currents is shown, and the applicability of maxwell-like equations to gravitational fields is substantiated.

Keywords: maxwell equations, electricity and magnetism, potentials and charges, forces and moments, interconversion of fields.

Author: Scientific Center Of The Togliatti State University (russian Federation).

I. INTRODUCTION

One often hears that Maxwell's equations "contain all electrodynamics" [1]. Meanwhile, a theory based on these equations does not provide a satisfactory answer to elementary questions about what an electric charge is and what causes the appearance of attractive and repulsive forces in it, how the conductivity and bias currents differ, or

the vortex electric and vortex-free magnetic fields, what the mechanism of their transformation, what is the physical meaning of the vector magnetic potential and how to avoid the postulation of the Lorentz force, etc., etc. Many phenomena have been discovered, the explanation of which runs into insurmountable difficulties. Some of them are quite well-known, for example, the demarcation of Maxwell's electromagnetic field theory with electromechanics, the inapplicability of Maxwell's equations for open currents; violation of Newton's 3rd law for cross currents; strange exceptions to the flow rule and features of the Faraday unipolar motor, violation of the energy conservation law by a pulsating electromagnetic field, the existence of a non-vortex component of the magnetic field and radiation of a non-electromagnetic nature, etc. [2].

All this gives rise to a natural desire to find more reliable foundations of electrodynamics. Such a basis, in our opinion, is a unified theory of the processes of transfer and conversion of any form of energy, called energy dynamics for brevity [3]. This theory differs from other fundamental disciplines in that it takes into account the heterogeneity of the systems under study and the presence of the vibrational form of energy, offering the most general form of the law of conservation of energy. In this article, we will try to set out its features in the shortest possible way and, on its basis, eliminate the paralogsms that are found in the analysis of the postulates put by Maxwell at the base of his equations [4].

II. ENERGY DYNAMICS AS A UNIFIED THEORY OF ENERGY CONVERSION PROCESSES

The object of the study of energy dynamics [3] is multivariate systems that have any properties and can be described as a whole by a finite number of state parameters Θ_i such as the mass of k -substances M_k , their charge Q_k , entropy S_k , momentum \mathbf{P}_k , etc.). Moreover, it proceeds from the concept of short-range action, according to which the energy of the system U does not just disappear at some points in space and appears at others, but is transferred through its boundaries by some energy carrier Θ_i through thermal conductivity, electrical conductivity, diffusion, radiation, etc. For such systems, the law of energy conservation in the form proposed by the Russian scientist N. Umov (1873) [5] is valid:

$$dU/dt + \oint \mathbf{j}_u d\mathbf{f} = 0, \quad (1)$$

where U is the internal energy of the system; \mathbf{j}_u is the density of its flow through the vector element $d\mathbf{f}$ of the closed surface of the fixed system of constant volume V in the direction of the external normal \mathbf{n} (Figure 1).

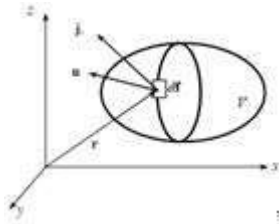

Figure 1: Energy flow across system borders

According to the concept of short-range incorporated into this equation, the energy U does not just disappear at some points in space and appears at others, but is transferred by energy carriers Θ_i through the boundaries of the system. This form of the law of conservation of energy takes into account the kinetics of real processes, without making any assumptions about the mechanism of energy transfer and the internal structure of the system, i.e., considering it to be a continuous medium.

We now take into account that the energy flux \mathbf{j}_u is composed of the \mathbf{j}_{uk} flows of the “partial” energy of the k -th type U_k , each of which is in turn expressed by the product of the energy flux \mathbf{j}_k and its potential ψ_k (specific energy), that is, $\mathbf{j}_{uk} = \psi_k \mathbf{j}_k = \psi_k \rho_k \mathbf{v}_k$, where \mathbf{v}_i is the rate of transfer of the k -th energy carrier through the fixed boundaries of the system, $\rho_k = d\Theta_k/dV$ is its density. Then

$$\mathbf{j}_u = \sum_i \mathbf{j}_{ui} = \sum_k \psi_k \mathbf{j}_k \quad (2)$$

Using the Gauss-Ostrogradsky theorem, expression (1) can be converted to the form $dU/dt + \int \nabla \cdot \mathbf{j}_u dV = 0$, which, after decomposing $\nabla \cdot (\psi_k \mathbf{j}_k)$ into independent components $\sum_k \psi_k \nabla \cdot \mathbf{j}_k + \sum_k \mathbf{j}_k \cdot \nabla \psi_k$ leads to the law of conservation of energy in the form:

$$dU/dt + \sum_k \int \psi_k \nabla \cdot \mathbf{j}_k dV + \sum_k \int \mathbf{j}_k \cdot \nabla \psi_k dV = 0 \quad (3)$$

If the average value $\bar{\psi}_k$ of the potential ψ_k and the average value $\mathbf{X}_k \equiv \bar{\nabla} \psi_k$ of the gradient of the potential $\nabla \psi_k$ are taken out of the integral sign, equation (3) can be expressed in terms of the parameters of the system as a whole, as is customary in classical thermodynamics:

$$dU/dt + \sum_k \bar{\psi}_k J_k + \sum_k \mathbf{X}_k \mathbf{J}_k = 0, \quad (\text{BTr}) \quad (4)$$

Here $J_k = \oint \mathbf{j}_k d\mathbf{f} = \int \nabla \cdot \mathbf{j}_k dV$ is the scalar flow of the k -th energy carrier through the system

boundaries; $\mathbf{J}_k = \int \rho_k \mathbf{v}_k dV = \Theta_k \bar{\mathbf{v}}_k$ is the vector flow of the same energy carrier, having the meaning of its momentum; $\rho_k = d\Theta_k/dV$, $\bar{\mathbf{v}}_k$ is the energy carrier density and the average rate of its transfer.

A more detailed picture of the processes occurring in heterogeneous systems can be obtained by expanding the velocity \mathbf{v}_i into independent translational \mathbf{u}_i and rotational $\mathbf{w}_i = \boldsymbol{\omega}_k \times \hat{\mathbf{r}}_k$ components.

$$\mathbf{v}_k = \mathbf{u}_k + \boldsymbol{\omega}_k \times \hat{\mathbf{r}}_k \quad (5)$$

where ω_k is the angular velocity of rotation of a unit volume of the system; r_k is the instantaneous radius of rotation of a unit volume of the system.

Then, along with the forces F_k in the equation of the law of conservation of energy, their torques $M_k = F_k \times r_k$ appear, and the law of conservation of energy takes a more general form:

$$dU/dt + \sum_k \bar{\psi}_k J_k + \sum_k F_k \cdot u_k + \sum_k M_k \cdot \omega_k = 0 \quad (6)$$

In this case, the energy exchange of the system with the environment is carried out in three ways, corresponding to its three sums. The first characterizes the transfer of partial energy $U_k = \int \psi_k \rho_k dV$ through the boundaries of the system *without changing its shape* [3]. The second and third sums (6) are associated with the movement and reorientation of the energy carrier Θ_k , i.e., with the work of W_k as a quantitative measure of the transformation of the energy of the k -th form U_k into some j -th form U_j .

As follows from the expanded form of the law of conservation of energy (6), *the number of arguments of energy U as a function of the state of the system is equal to the number of independent processes taking place in it.* Moreover, for each form of internal (intrinsic) energy U_k there exists and can be found an independent energy carrier Θ_k and its potential ψ_k as its extensive and intensive measures. In the internal equilibrium (homogeneous) state, these energy carriers are uniformly distributed over its volume V . However, in an inhomogeneous state, the radius vector of their center R_k shifts from its initial position, which coincides with the center occupied by the volume system, by a certain amount $\Delta r_k = u_k dt$, and in more in the general case, it rotates by the spatial angle $d\varphi_i = \omega_i dt$. If the state of internal equilibrium is taken as the zero point of the displacement vector R_k , then when the system deviates from it, “distribution moments” of energy carriers $Z_k = \Theta_k R_k$ with

shoulder R_k occur, the time derivatives of which determine the energy carrier flows $J_k = dZ_k/dt = \Theta_k \bar{v}_k$. Then the energy of the system as a function of its state takes the form $U = \sum_k U_k(\Theta_k, r_k, \varphi_r)$, which allows us to give equation (6) the character of enhanced equality (identity):

$$dU \equiv \sum_k \Psi_k d\Theta_k + \sum_k F_k \cdot dr_k + \sum_k M_k \cdot d\varphi_k \quad (7)$$

where $\Psi_k \equiv \partial U / \partial \Theta_k$; $F_k \equiv \partial U / \partial r_k$; $M_k \equiv \partial U / \partial \varphi_k$ are generalized potentials, forces and their torques in their general physical understanding [3]. With this approach, it becomes especially obvious that the thermodynamic forces X_k , found under the constancy of all other variables, including Θ_k , represent the specific value of the force F_k in its general physical sense and have the meaning of the strength of the corresponding force field $X_k = F_k / \Theta_k$. This confirms that any force fields represent the stress state of the material system. Moreover, any forces X_k and flows J_k in any disciplines that operate on these concepts are given unambiguous meaning of the average gradient of the corresponding potential X_k

$\equiv \bar{\nabla} \psi_k$ and the average momentum $J_k = \Theta_k \bar{v}_k$ of the vibrational, translational and rotational and motion of the k -th energy carrier. It follows that the first sum (6) characterizes the equilibrium energy transfer U_k through the boundaries of the system while maintaining its shape, and its 2nd and 3rd sums are the nonequilibrium part of energy exchange associated with its transformation. At the same time, it becomes obvious that, in view of the equality of the displacement vector dr_k to the displacement of the energy carrier dr in the Cartesian coordinate system, any force $F_k = (\partial U_k / \partial r) = \nabla U_k$, i.e., it represents the gradient of the corresponding energy form U_i , and the force fields are generated by the inhomogeneous energy distribution Θ_k in space.

It is characteristic that with this (systemic and phenomenological) approach, equations (6) do not turn into inequalities, despite the explicit inclusion of the non-static (irreversibility) of the processes under consideration in them. This

solves the most important “problem of thermodynamic inequalities”, which still hinders the application of thermodynamics to real (occurring at a finite speed) processes. It is also important that identity (7) covers all possible processes in an isolated system involving any substances. All this makes identity (7) the most complete (today) expression of the law of conservation of energy and the definition of the concept of energy and its arguments, excluding their free interpretation.

III. ENERGY DYNAMICS AS AN ALTERNATIVE BASIS FOR ELECTRODYNAMICS

We apply the mathematical apparatus of energy dynamics to “current-carrying” systems with the processes of polarization, magnetization and the conversion of electrical energy into any other form in it. This apparatus eliminates the need to search for the physical meaning of the parameters used by electrodynamics. For such systems, $U_e = U_e(Q, \mathbf{r}_e, \boldsymbol{\varphi}_e)$, where Q , \mathbf{r}_e , $\boldsymbol{\varphi}_e$ is the electric charge, its displacement vector and its spatial angle in the reference frame associated with the center of the volume occupied by the system. The remaining parameters in accordance with equation (7) acquire the meaning of the electric potential $\varphi \equiv \partial U / \partial Q$, the moment of charge distribution $\mathbf{Z}_e = Q\mathbf{R}_e$, current $\mathbf{I} = Q\mathbf{v}_e$, electric field strength $\mathbf{X}_e = \mathbf{E} = \partial U / \partial \mathbf{Z}_e$, electric force $\mathbf{F}_e = Q\mathbf{E}$ and its torque $\mathbf{M}_e = \partial U / \partial \boldsymbol{\varphi}_e$. This makes the laws of electrodynamics a special case of general physical principles that are valid for the processes of conversion of any form of energy, making it possible to obtain its basic laws in a more direct and short way.

One of the main issues concerns the work carried out by the current-carrying system. It is generally accepted that “a magnetic field, as opposed to an electric field, does not work on the charges moving in it (since the force acting on the charge is perpendicular to its speed.” [6]. Therefore, modern electrodynamics cannot give an intelligible answer to the question, what are the forces they rotate the rotors of numerous electric

motors, electromagnetic lifts, etc. The answers to these questions are given by energy dynamics.

According to identity (7), an electric charge is capable of performing three independent types of work dW_e^1 , corresponding to three sums (7). Such are the work of introducing a charge into any region of the system with potential φ , described by the expression:

$$dW_e' = \varphi dQ, \quad (8)$$

the work of charge redistribution over the volume of the system associated with its polarization and the appearance of a charge displacement vector $d\mathbf{r}_e = \mathbf{u}_e dt$

$$dW_e'' = \mathbf{X}_e \cdot d\mathbf{Z}_e = \mathbf{F}_e \cdot d\mathbf{r}_e = - Qd\varphi \quad (9)$$

and the work of reorienting this vector $d\mathbf{Z}_e = Q(d\boldsymbol{\varphi}_e \times \mathbf{R}_e)$ in space (rotation through an angle $d\boldsymbol{\varphi}_e$)

$$dW_e''' = \mathbf{F}_e \cdot (d\boldsymbol{\varphi}_e \times \mathbf{R}_e) = - \mathbf{M}_e \cdot d\boldsymbol{\varphi}_e \quad (10)$$

For substances with a “congenital” ordered charge movement (for example, permanent magnets), another energy carrier appears, which is the charge momentum $Q\mathbf{v}_e$, usually called the “molecular current”) and the associated magnetic component U_m of electrokinetic energy U_e . The vector nature of the current \mathbf{I} as an energy carrier leads to the fact that the potential $\psi_m = (\partial U / \partial \Theta_m)$ acquires a vector character and the meaning of the speed of the ordered charge motion \mathbf{v}_e :

$$\boldsymbol{\psi}_m \equiv (\partial U / \partial \mathbf{I})_q = \mathbf{v}_e \quad (11)$$

In this case, the magnetic field strength \mathbf{X}_m takes on the meaning of a vector gradient of the charge velocity:

$$\mathbf{X}_m \equiv \text{Grad } \mathbf{v}_e \equiv \nabla \mathbf{v}_e. \quad (12)$$

This “magnetomotive” force \mathbf{X}_m is a 2nd-rank tensor that can be decomposed into the scalar component $X_m' = \nabla \cdot \mathbf{v}_e$ (trace of the tensor) and two components of vector nature: symmetric (vortex-free) $\mathbf{X}_m'' = (\nabla \mathbf{v}_e)^s$ and antisymmetric (vortex) $\mathbf{X}_m''' = (\nabla \mathbf{v}_e)^a$. The moment of their

¹ The sign of incomplete differential “ d ” emphasizes that elementary work dW depends on the process path.

current distribution \mathbf{Z}_m , acquires the same tensor rank, which is defined in this case as the external product of current vectors $\mathbf{I} = Q\mathbf{v}_e$ and current displacement $\Delta\mathbf{R}_m$, i.e. $d\mathbf{Z}_m = Q\mathbf{v}_e \times \mathbf{R}_m$, as well as the magnetic $\mathbf{J}_m = d\mathbf{Z}_m/dt = \mathbf{I} \times \mathbf{v}_m$. This circumstance determines the specificity of the magnetic field \mathbf{X}_m , arising due to the ordering of molecular currents and their redistribution over the volume during magnetization of ferromagnets, as well as due to the inhomogeneous distribution of current over the cross section of conductors (such as a skin-effect).

However, in electrodynamics, a magnetic field is traditionally introduced as a rotor of the vector potential $\mathbf{B} = \nabla \times \mathbf{A}$ [1]:

$$\mathbf{A} = (\mu_0/4\pi) \int (\mathbf{j}_e/R_e) dV, \quad (13)$$

where μ_0 is the magnetic permeability of the medium; R_e - the removal of the field point from the current \mathbf{j}_e .

The physical meaning of this potential and its relationship with the work done by the magnetic field remains unclear until recently, and attempts to break free of its ambiguity by imposing additional conditions (calibrations) of Coulomb, Poincare, Lorentz, the brothers London, Weil, Fock - Schwinger, Landau and etc. - unsatisfactory [1]. The reason for these difficulties is that its vortex component $\mathbf{X}_m''' = (\nabla \mathbf{v}_e)^a$, which is proportional to the angular velocity of the charge $\boldsymbol{\omega}_e$, is taken as a magnetic field \mathbf{B} . Such a "reduction" of the magnetic field (lowering its tensor rank) excludes its divergent part $\nabla \cdot \mathbf{A}$ from consideration (Nikolaev's strength) [7] and distorts the physical meaning of the field strength \mathbf{H} , which in reality is the vortex-free component of the magnetic field and is proportional to the current \mathbf{I} and the potential $\mathbf{X}_m'' = (\nabla \mathbf{v}_e)^s$. Landau also pointed to the vortex-free nature of this quantity the fact that it "should have been sought in the form $\mathbf{H} = -\nabla\psi$, since $\text{rot}\mathbf{H}$ is equal to zero." [5]. The fact that the quantity \mathbf{A} does not correspond to the concept of potential is at least indicated by the fact that this quantity is proportional to the total current $\mathbf{I} = \int \mathbf{j}_e dV$ is an

extensive parameter of the system, which is not characteristic of any of the potentials ψ_i . As we see, the true vector magnetic potential is the charge velocity \mathbf{v}_e or its vector components \mathbf{w}_e and \mathbf{u}_e . [6].

If we take into account the tensor character of the magnetic field \mathbf{X}_m , then the work of the magnetic field is expressed by the internal product (convolution) of the tensors \mathbf{X}_m and \mathbf{Z}_m . This work can also be decomposed into three components corresponding to three sums (8). According to (8), the first of them, dW_m' , occurs when the energy carrier \mathbf{I} is introduced into the space region with the potential ψ_e under the conditions of constancy of all other independent variables, including the charge Q . It is determined by the expression.

$$dW_m' = \mathbf{v}_e \cdot d\mathbf{I} = Qdv_e^2/l \quad (14)$$

and is expressed in strengthening the disordered (vibrational or rotational) molecular motion of a free or bound charge. It is this work that "charges" the body and raises the petals of the electroscope.

To find other types of magnetic work, dW_m'' и dW_m''' , we decompose the displacement velocity of the "current tubes" $\mathbf{u}_m = d\mathbf{R}_m/dt$ similarly to (5), into the translational \mathbf{u}_m and rotational $\mathbf{w}_m = \boldsymbol{\omega}_m \times \mathbf{R}_m$ component. The first of them, dW_m'' , characterizes the shift of the current elements $d\mathbf{I}$ during its redistribution over the system during the polarization of magnets (creating an inhomogeneous current distribution in them). It is expressed by the scalar product of the force $\mathbf{X}_m'' = \mathbf{H}$ by the "translational" component $d\mathbf{Z}_m'' = \mathbf{I} \times \mathbf{u}_m dt$ tensor $d\mathbf{Z}_m$ and is determined by the expression:

$$dW_m'' = \mathbf{X}_m'' \cdot d\mathbf{Z}_m'' = \mathbf{F}_m \cdot d\mathbf{r}_m, \quad (15)$$

where $d\mathbf{r}_m = \mathbf{u}_m dt$; $\mathbf{F}_m = \mathbf{I} \times \mathbf{H}$ is the magnetic component of the Lorentz force. This work is accomplished, for example, in the process of magnetization of the material (creation of the "north" and "south" poles of the magnet) or when the current is displaced into the surface layer of the conductor ("skin effect").

The last of the magnetic works, dW_m''' , occurs when the magnetization is reoriented, for example, when a ferromagnet rotates in a magnetic field \mathbf{H} . It is expressed by the product of the vortex component $\mathbf{X}_m''' = \mathbf{B}$. In the force \mathbf{X}_m by

$$dW_m''' = \mathbf{X}_m''' \cdot d\mathbf{Z}_m''' = \mu_o(\mathbf{I} \times \mathbf{H}) d\boldsymbol{\varphi}_m \mathbf{u}_m dt = \mu_o \mathbf{F}_m \cdot (d\boldsymbol{\varphi}_m \times \mathbf{R}_m) = -\mathbf{M}_m \cdot d\boldsymbol{\varphi}_m \quad (16)$$

where $\mathbf{M}_m = \mu_o \mathbf{F}_m \times \mathbf{R}_m$ is the torque of the Lorentz force $\mathbf{F}_m = \mathbf{I} \times \mathbf{H}$.

As we see, finding the Lorentz force does not require either postulation or the involvement of GR. This force differs from other forces only in that it is normal with respect to the current, since it is displaced in the transverse direction. When this displacement takes on the character of rotation, the work is performed by the torque of the Lorentz magnetic forces. This refutes the conventional wisdom that magnetic forces do not work, because they are always perpendicular to the current [6].

Thus, energy dynamics eliminates the difficulties of electrodynamics associated with the uncertainty of the concept of a vector potential, with the exception of its divergent component, the determination of the magnetic field based on it, the need to postulate the Lorentz force, the impossibility of its work and the existence of a vortex-free component of the magnetic field. Moreover, it reveals the reasons why Maxwell's equations could not be obtained from its primary principles [7].

IV. AN ALTERNATIVE FORM OF MAXWELL'S EQUATIONS

From the law of conservation of energy (4) under conditions of isolation of the system ($dU/dt = 0$, $J_k = 0$), its 2nd sum directly vanishes:

$$\sum_k \mathbf{X}_k \cdot \mathbf{J}_k = 0 \quad (17)$$

The forces \mathbf{X}_k included in this expression characterize the strength of the corresponding field, which leads to an unambiguous interpretation of the force field as the stress state

of the medium. According to (16), in the process of converting some i -th form of the ordered energy of the system U_i to the j -th U_j , the relation

$$\mathbf{X}_i \cdot \mathbf{J}_i = -\mathbf{X}_j \cdot \mathbf{J}_j \quad (18)$$

It follows, in particular, that in the process of converting the energy of an irrotational electric field $\mathbf{X}_e = \mathbf{E}$ into an irrotational magnetic field $\mathbf{X}_m = \mathbf{H}$, the relation

$$\mathbf{J}_m / \mathbf{X}_e = -\mathbf{J}_e / \mathbf{X}_m \quad (19)$$

In electrodynamics, following Faraday, the magnetic flux \mathbf{J}_m is the total time derivative of the "magnetic coupling flux" $\mathbf{J}_m = d\mathbf{B}/dt$, and \mathbf{J}_e is the "total current" as the sum of the Maxwell bias current $\mathbf{J}_e^c = (\partial\mathbf{D}/\partial t)$ and current conductivity \mathbf{J}_e^n as a convective component $(\mathbf{v}_e \cdot \nabla) \mathbf{D}$ of the total derivative of the electric induction vector

$$d\mathbf{D}/dt = (\partial\mathbf{D}/\partial t)_r + (\mathbf{v}_e \cdot \nabla) \mathbf{D} \quad (20)$$

If we now denote the ratio $\mathbf{J}_e / \mathbf{X}_m$ by the coefficient L_{em} , and $\mathbf{J}_m / \mathbf{X}_e$ - by the coefficient L_{me} , then relation (19) will appear as a pair of equations:

$$L_{em} \mathbf{E} = -d\mathbf{B}/dt \quad (21)$$

$$L_{me} \mathbf{H} = d\mathbf{D}/dt \quad (22)$$

The first of them reflects the Faraday law of electromagnetic induction, according to which the deflection of the galvanometer needle (a value proportional to the field \mathbf{E}) is determined by the rate of change of the magnetic flux (expressed by the number of magnetic field lines). From the corresponding Maxwell equation

$$\nabla \times \mathbf{E} = -\partial\mathbf{B}/\partial t \quad (23)$$

expression (21) differs in that it does not postulate the existence of a "vortex" electric field, which is why $\mathbf{E} \neq -\nabla\phi$, and does not exclude the

“convective” component $(\mathbf{v}_m \cdot \nabla) \mathbf{B}$ of the bias in the expression of the total differential of the magnetic induction vector:

$$d\mathbf{B}/dt = (\partial\mathbf{B}/\partial t)_r + (\mathbf{v}_m \cdot \nabla)\mathbf{B}, \quad (24)$$

which is due to the redistribution of current over the conductor cross section and is responsible, in particular, for the skin effect.

Equally, equation (22) differs from the second Maxwell equation

$$\nabla \times \mathbf{H} = \mathbf{J}_e^p + \partial\mathbf{D}/\partial t \quad (25)$$

by replacing the “rot” operator by the coefficient L_{me} and the fact that it does not exclude the presence in the term $(\mathbf{v}_e \cdot \nabla) \mathbf{D}$ along with the conduction current \mathbf{J}_e^p (taking into account the charge motion relative to the conductor), the “convective current” \mathbf{J}_e^k associated with the movement of the conductor or dielectric in the magnetic field. Taking this component into account makes it possible to explain, for example, the appearance of a magnetic field during rotation of an electrically neutral metal disk (the Rowland – Eichenwald and Rentgen – Eichenwald effects), as well as the polarization of the dielectric plate when it moves in a magnetic field (Wilson – Barnett effect) [1]. The movement of the charge along with the disk or plate also explains why in unipolar Faraday motors the emf arises where the $\partial\mathbf{B}/\partial t$ “flux” does not change, and does not occur where this flux changes. This eliminates the need to use different laws of force for the case of a moving contour and a changing field, noted by R. Feynman [9]. Thus, two pairs of equations: (21), (22), and (20), (24), along with their extreme simplicity, non-propulsive nature and complete symmetry, cover a wider range of phenomena than Maxwell's equations. This makes them alternative to these equations.

On the other hand, the “Maxwell-like” equations (20) and (21) reveal the reasons why Maxwell had to resort to a number of postulates. The fact is that the equations of the law of conservation of mechanical and internal energy that existed at that time did not contain any specific parameters of the “electrotonic” state and could not serve as

the basis for obtaining relations (19). They were a consequence of energy transformation law (4), in which the forces \mathbf{X}_i and flows \mathbf{J}_i are of a vector nature. This circumstance corresponds to the universal Curie symmetry principle, according to which only phenomena of the same tensor rank can interact [10]. Therefore, Maxwell's equations (23) and (25), in principle, cannot connect the vortex magnetic field of the 2nd tensor rank \mathbf{X}_m with the electric field of the 1st tensor rank \mathbf{E} .

Only vortex or vortex-free components of these fields can interact, which required the postulation of the vortex nature of the electric field. This necessitated the introduction of a bias current, which would shorten the conduction currents to create a closed loop with current and made it possible to express this field with a rotor. Hence the assumption of a bias current flowing equal to the conduction current in vacuum, as well as the limited nature of the Maxwell equations by closed currents. Meanwhile, the bias currents do not continue the conduction currents, but are directed towards them, which causes, in particular, the disappearance of their sum at the end of the capacitor charging process [10]. We no longer touch upon the contradictions associated with the interpretation of electromagnetic waves in a vacuum as light [12]. All this makes the replacement of Maxwell's equations with “Maxwell-like” equations (21.22) and (20.24) very, very than appropriate, especially considering their applicability to any natural phenomena.

V. MAXWELL-LIKE GRAVITY EQUATIONS

The idea of the unity of the description of the relationship between electromagnetic and gravitational fields, laid down in the law of conservation of energy (7), was first realized in the equations of gravitoelectromagnetism (GEM) by O. Heaviside (1893) when he reformulated the original Maxwell equations [13]. In them, as an analogue of the charge density ρ_e , current density $\rho_e \mathbf{v}_e$, electric strength \mathbf{E} and magnetic fields \mathbf{B} , etc., the same parameters of the gravitational field (with the index “g”) were considered, that is ρ_g , $\rho_g \mathbf{v}_g$, \mathbf{E}_g , \mathbf{B}_g etc. In this case, the gravitational

force, like the Lorentz force, was assumed to consist of two components, one of which, $\rho_g \mathbf{E}_g$, was responsible for the acceleration of particles, and the other, $\rho_g \mathbf{v}_g \times \mathbf{B}_g$, for their rotation. Owing to this, the Heaviside equations for the GEM had the same form as for the EMF.

However, for this, he had to assume the possibility of converting a relatively weak gravitational field into an electromagnetic (and vice versa) and neglect the fundamental difference between the gravitational field from electric and magnetic fields, which are characterized by both attraction and repulsion. Finally, we also had to admit the presence of a vortex component in the gravitational field and the equality of the propagation velocity of gravity c_g of the speed of light c . All this in those days had no experimental grounds and only strengthened the postulate nature of Maxwell's equations themselves.

However, for this, he had to assume the possibility of converting a relatively weak gravitational field into an electromagnetic (and vice versa) and neglect the fundamental difference between the gravitational field from electric and magnetic fields, which are characterized by both attraction and repulsion. Finally, we also had to admit the presence of a vortex component in the gravitational field and the equality of the propagation velocity of gravity c_g of the speed of light c . All this in those days had no experimental grounds and only strengthened the postulate nature of Maxwell's equations themselves.

All this can be avoided by applying relations (19), which follows from the law of conservation of energy and therefore is valid for any of its forms and any components of gravitational and electromagnetic fields of the same tensor rank. In particular, for the vortex (axial) components \mathbf{X}_m and \mathbf{X}_g of gravitational and electromagnetic fields, relation (19) is more conveniently written on the basis of expression (6) through the corresponding torques \mathbf{M}_e , \mathbf{M}_g and angular velocities $\boldsymbol{\omega}_e$ and $\boldsymbol{\omega}_g$:

$$\mathbf{M}_e / \mathbf{M}_g = - \boldsymbol{\omega}_g / \boldsymbol{\omega}_e. \quad (26)$$

This expression directly implies the fundamental possibility of tornadoes, tornadoes, cyclones and anticyclones, storms and hurricanes in the atmosphere of our planet when our planet moves in outer space with different vorticity of the "hidden matter" of the Universe. It is possible that these cosmo physical factors are responsible for other geophysical phenomena on Earth [14].

VI. AN ALTERNATIVE TO MAXWELL'S WAVE EQUATIONS

As follows from the energy conservation law (6), the partial energy U_k of any energy carrier Θ_k is a function of time t and the position \mathbf{r}_k of its center, i.e., $U_k = U_k(t, \mathbf{r}_k)$. In this case, its complete change in time includes two components

$$dU_k/dt = \partial U_k / \partial t + (\mathbf{v}_k \cdot \nabla) U_k. \quad (27)$$

At its core, this expression corresponds to the wave equation in its so-called "single-wave" approximation. Unlike the "dynamic" second-order equation corresponding to Maxwell's equations, it describes a wave propagating in only one direction (from the source). This kind of wave equation is often called "kinematic" [15]. Its belonging in the wave equations becomes especially evident if expression (27) is represented in the form of a wave (with the damping (or excitation) function $\Phi(\mathbf{r}, t) = dU_k/dt$:

$$\partial U_k / \partial t + \mathbf{v}_k \cdot (\partial U_k / \partial \mathbf{r}) = \Phi(\mathbf{r}, t), \quad (28)$$

where \mathbf{v}_k is the phase velocity of the wave.

This equation is based on the law of conservation of energy and, therefore, is valid for describing the vibrational motion of any energy carrier Θ_k . For nonlinear media with dispersion at low frequencies, it is known as the Klein – Gordon equation, and with dispersion at high frequencies it is known as the Korteweg – de Vries equation [15]. It is applicable to describe the radiation of energy into the environment of the system. According to (7), $(\partial U_k / \partial \mathbf{r}) = \mathbf{F}_k = \Theta_k \mathbf{X}_k$, so that the second term in (27) characterizes the vibration power of the k th energy carrier Θ_k in the system.

Under stationary conditions ($\partial U_k/\partial t = 0$), this oscillatory process is supported by the excitation source $\Phi(\mathbf{r}, t)$ and is accompanied by radiation with a certain frequency spectrum ν . The power of this radiation dU_k/dt is expressed similarly to other types of work $dW_e/dt = \mathbf{X}_k \cdot \mathbf{J}_k$, где $\mathbf{J}_k = \Theta_k \mathbf{v}_k$, where $\mathbf{J}_k = \Theta_k \mathbf{v}_k$.

Only the medium, the interaction of which with the substance does not depend on its structure and any other properties besides mass (amount of substance), can transfer this energy in space of countless k-elements and their compounds. This is the only - gravitational - energy whose carrier (called "ether", "hidden mass", "primary", "unstructured", "dark", "non-baryonic" matter, "dark energy", etc.) is current data at least 95% of the mass of the entire universe. Now that a lot of non-electromagnetic radiation and longitudinal waves have been detected, but no magnetic component of the electromagnetic field (EMF) has been found, which is equal in electric power, there is no reason to consider this field to be a carrier of radiant energy [12]. This is all the more true that the notion of EMF as a material medium, detached from its source and transferring energy "after it has left one body and has not yet reached another" [4], violates the law of conservation of energy due to the in-phase variation of the vectors \mathbf{E} and \mathbf{H} in the expression of EMF energy $U = \epsilon_0 \mathbf{E}^2/2 + \mu_0 \mathbf{H}^2/2$ [2].

Thus, there is an alternative to the Maxwell wave equations, which at one time played an outstanding role in the development of radio engineering and electronics, but are currently becoming a brake on the development of the latest energy and information transfer technologies.

REFERENCES

1. Whittaker E. History of the theory of ether and electricity. - Moscow - Izhevsk, 2001.
2. Kann K.B. Electrodynamics of common sense,- Lamb.Acad.Publ., 2014 (in Russian).
3. Etkin V. Energy dynamics (Thermodynamic Fundamentals of Synergetics) .- N.Y., 2011; .Etkin V.A. Energy dynamics (synthesis of

theories of energy transfer and transformation) St. Petersburg, Nauka, 2008. (in Russian).

4. Maxwell J. Treatise on Electricity and Magnetism.- London, 1873.
5. Umov N.A. Selected Works. M.L., 1950. (in Russian).
6. Landau LD, Livshits EM. Theoretical Physics. T.8. Electrodynamics of continuous media.- M., Nauka, 1982.
7. Nikolaev G.V. Consistent electrodynamics. Theories, experiments, paradoxes. TPU, 1997. (in Russian).
8. Etkin V.A. Thermodynamic Derivation of Maxwell's Electrodynamics Equations. // Global Journal of Physics, 3 (1) .2015). 1-8.
9. Feynman R., Leighton R., Sands M. The Feynman lectures on physics. V.2, London, 1964.
10. Curie P. On symmetry in physical phenomena: symmetry of electric and magnetic fields // Pierre Curie. Selected Works, M., 1966. p. 95-113 (in Russian).
11. Etkin V.A. Paralogsms in Maxwell's theory. // Research in the field of applied sciences. (Sat. proceedings of scientific conf.). Arad (Israel), 2015.
12. Etkin V.A. To the non-electromagnetic theory of light. // World Scientific News, 80 (2017).
13. Heaviside O. A gravitational and electromagnetic analogy. The Electrician, 1893.
14. Schnol S. E. Cosmophysical factors in random processes. - Stockholm, Svenska fysikarkivat, 2009.
15. Crawford F. Berkeley Physics course. V. 3. Waves.- McGraw-Hill, 1968.

This page is intentionally left blank



Scan to know paper details and
author's profile

I-clean of Cabin Aircon Filter

Abhinay Chakravarty, Yashwanth Kamath, Abhishek Jayadev & Ravikant Ingole

ABSTRACT

Many drivers pay little attention to their cabin air filters & some don't even know that their car/SUV/light truck likely contains this part, which plays an important role in keeping pollutants out of the passenger and driver's compartment. Cabin air filters have been standard features on most vehicles & they filter air that flows through cars' HVAC, to block dust, smog and other pollutants and irritants, including small dried leaves. Since the vehicle's air conditioning system will have to work harder if the filter is clogged & no fresh air will be circulated inside the car. A dirty cabin filter can also cause unpleasant smell from the air conditioner and can cause allergic reactions.

Keywords: dust, particulate matter, respiratory issues, clean air in car, auto cleaning.

Classification: FOR Code: 050399

Language: English



London
Journals Press

LJP Copyright ID: 392996

Print ISSN: 2631-8474

Online ISSN: 2631-8482

London Journal of Engineering Research

Volume 20 | Issue 2 | Compilation 1.0



© 2020. Abhinay Chakravarty, Yashwanth Kamath, Abhishek Jayadev & Ravikant Ingole. This is a research/review paper, distributed under the terms of the Creative Commons Attribution-Noncommercial 4.0 Unported License <http://creativecommons.org/licenses/by-nc/4.0/>, permitting all noncommercial use, distribution, and reproduction in any medium, provided the original work is properly cited.

I-clean of Cabin Aircon Filter

Abhinay Chakravarty^α, Yashwanth Kamath^σ, Abhishek Jayadev^σ & Ravikant Ingole^θ

ABSTRACT

Many drivers pay little attention to their cabin air filters & some don't even know that their car/SUV/light truck likely contains this part, which plays an important role in keeping pollutants out of the passenger and driver's compartment. Cabin air filters have been standard features on most vehicles & they filter air that flows through cars' HVAC, to block dust, smog and other pollutants and irritants, including small dried leaves. Since the vehicle's air conditioning system will have to work harder if the filter is clogged & no fresh air will be circulated inside the car. A dirty cabin filter can also cause unpleasant smell from the air conditioner and can cause allergic reactions.

Solution to this problem is to have an automatic AC filter cleaning mechanism, where the filter is fitted into a filter housing, using an Automatic Cleaning Brush which moves on the coated filter from its home position to the dust collection box position, while sweeping the dust. The dust

catcher puts the dust in the dust cavity/box below it. Once the cleaning is over, the brush moves back to its initial position. It will work by means of a power screw simple machine mechanism as explained in the methodology & a dust collector will also be placed at the home position. This brush moves twice over the dirty filter to increase the dust transfer capacity. Automatic filter cleaning ensures a dust-free filter, resulting in the air coming out of the AC being clean and fresh at all times. Cabin air filters prevent pollutants from entering your vehicle.

Keywords: dust, particulate matter, respiratory issues, clean air in car, auto cleaning.

Author α σ ρ θ: Department of Car Design and Chassis, 5 Department of CDM Mercedes-Benz Research & Development India, Embassy Crest, Plot No 5P, Road number 16, KIADB Export Promotion Industrial Area, Whitefield, BANGALORE - 560066, Karnataka, INDIA.

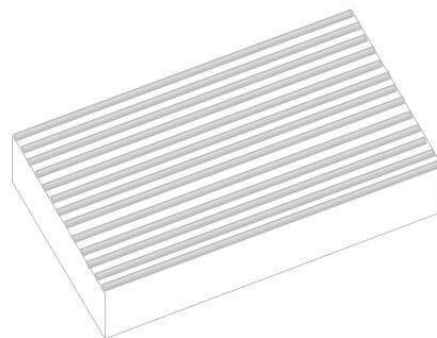

Fig. 1

I. TASK - WHY

The vehicle's air conditioning system will have to work harder if the filter is clogged & no fresh air will be circulated inside the car. A dirty cabin filter can also cause unpleasant smell from the air

conditioner and can cause allergic reactions. To avail the fresh air, one has to wait for next service which would be once in 15000Kms or 6 months which is earlier. Cabin air filters cost around 15 to 25 Euros. Mechanics charge between 40 and 100

Euros for parts and labor, depending on the vehicle's make and model. This turns out to be expensive.

II. HYPOTHESIS – ASSUMPTION

- The brush length is as much as the depth of the fleet.

- The brush does not damage the material of the filter.
- The shape of the air filter is rectangular.

III. STRATEGY → HOW / METHOD

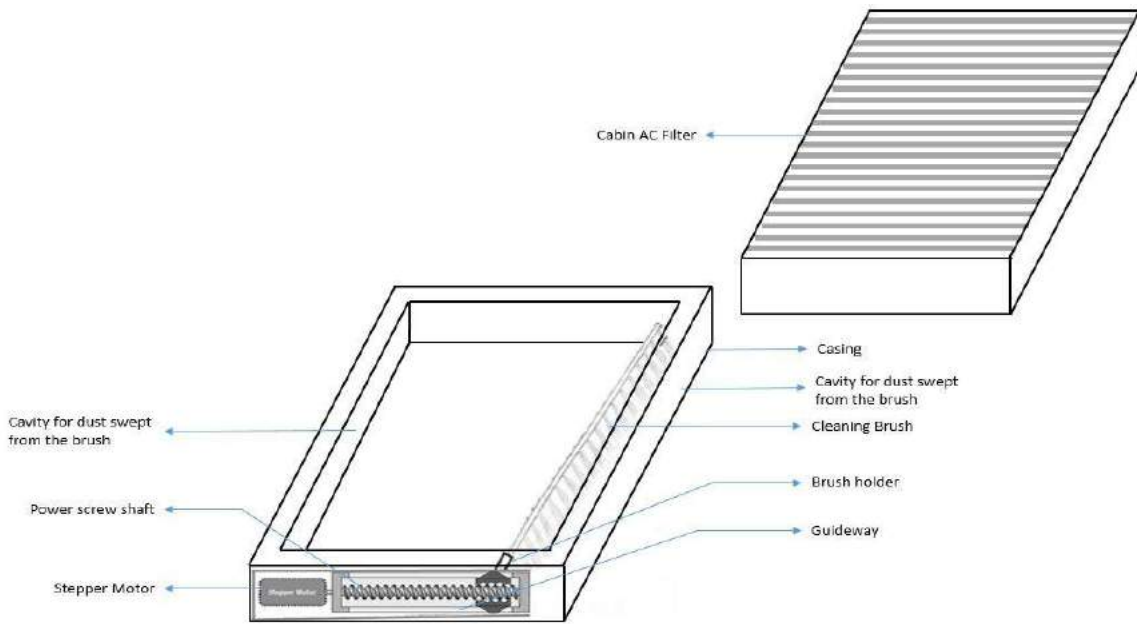

Fig.2

Automatic AC filter cleaning mechanism, where the filter is fitted into a casing/filter housing, using an Auto Cleaning Brush which moves on the coated filter from its home position to the dust collection box position, while sweeping the dust. The dust catcher puts the dust in the cavity provided in the casing. Once the cleaning is over, the brush moves back to its initial position. It will work by means of a power screw simple machine mechanism & a dust collector cavity will also be provided at the home position. This brush moves twice over the dirty filter to increase the dust transfer capacity. Auto filter cleaning ensures a dust-free filter, resulting in the air coming out of the AC being clean and fresh at all times. The Stepper motor which will be programmed for both clock wise and anti-clock wise rotation and the nut moves linearly along the shaft and fixed to the guideway. The nut is fixed to a holder which holds the brush firmly & when the motor rotates the

motion is passed on to the screw shaft and then to the holder with the help of the nut in-turn causing the linear motion which helps the auto cleaning brush to move on the air filter fleets cleaning and dust and accumulating in the dust collector cavity.

The auto cleaning feature can be activated once the airflow sensor detects drop in air flow rate through the filter. This functionality of cleaning the filter can also be initiated by the driver, who gets a warning sign in the instrument cluster, about the reduction in the air flow rate, through available inputs.

The stepper motor assembly and the brush are incorporated in the casing. The cabin AC filter is installed into this casing assembly. This enables the easy AC filter replacement.

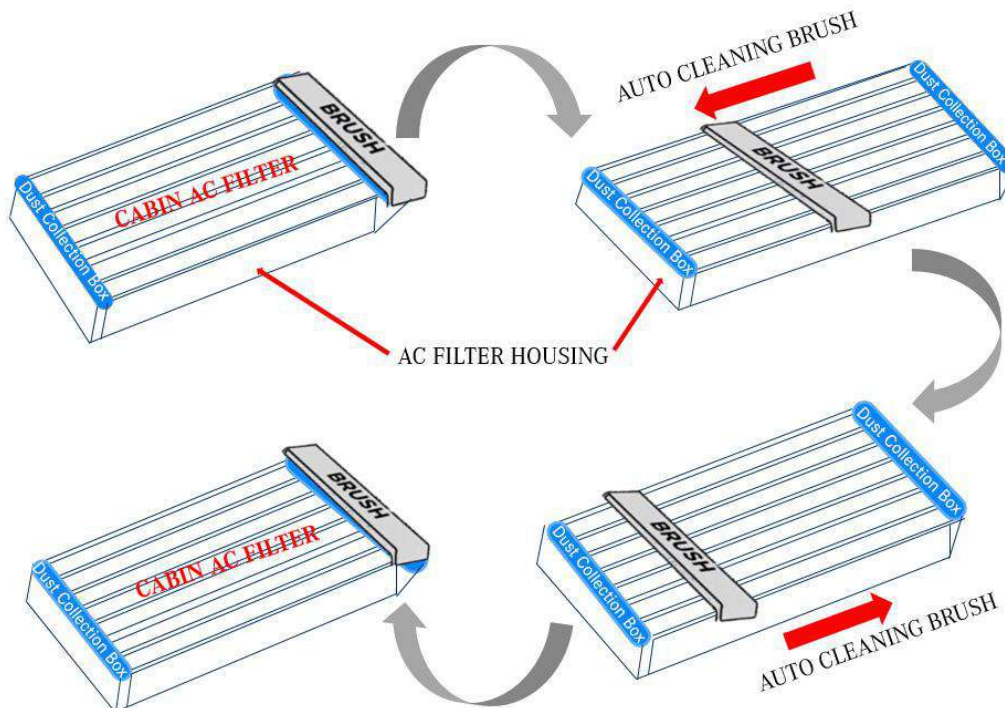
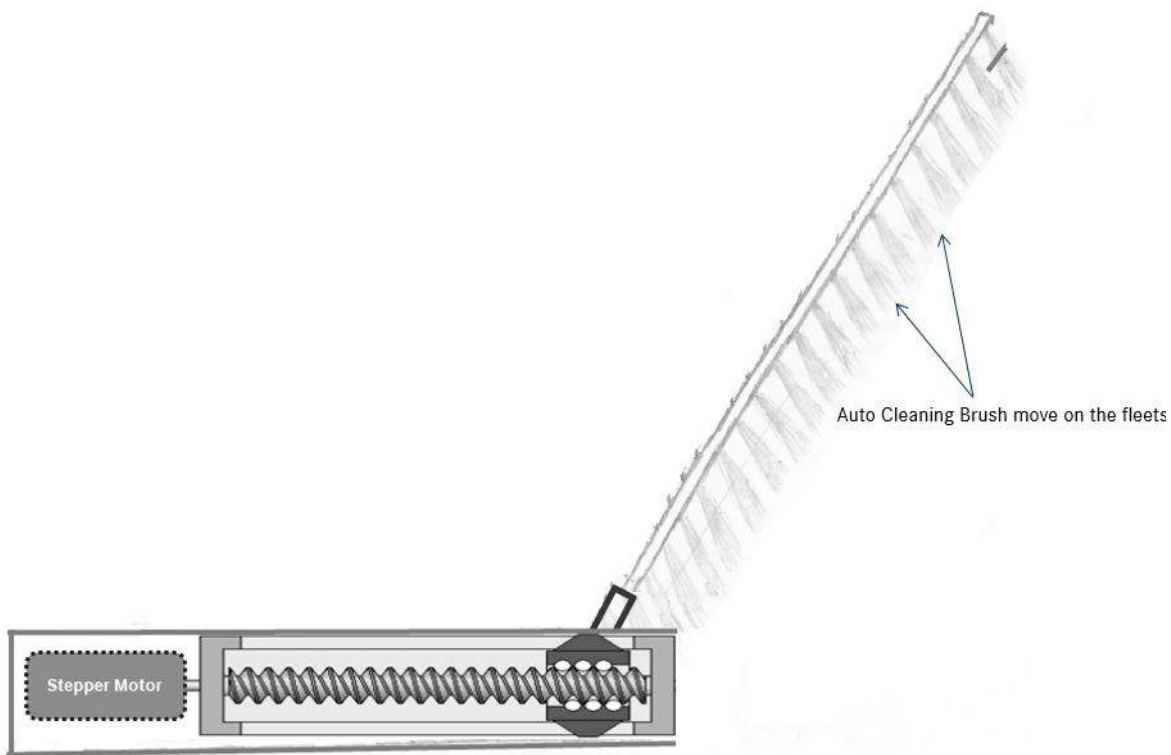

IV. DISCUSSION & TRANSFERABILITY

This mechanism can be installed across all car types and models. The only design consideration

to be taken is for the additional space for the dirt collection box.

V. ADVANTAGES & DISADVANTAGES

5.1 Pros

- Cost effective.
- Long filter life.
- Auto filter cleaning increases the efficiency of air filter performance.
- It prevents dust accumulation and always keeps the filter clean. It prevents the bacteria that cause unpleasant odours and keeps you feeling fresh and comfortable.
- It maintains the same performance like that of a new air filter and one can enjoy comfortable air conditioning inside the car.

5.2 Cons

- Additional space has to be provided to accommodate casing which includes stepper motor mechanism, brush and the dust collection boxes.

VI. RESULTS & CONCLUSION

This concept would prove to be a proactive option to avoid any dust entering the car cabin through air filter thus protecting the car interiors and occupants. This is beneficial to the occupants and also prevents frequent cleaning costs that would be incurred when the dust accumulates in the car cabin.

REFERENCES

1. Air filter functionality
<https://www.cartalk.com/content/service-your-car>
2. Types of Air filters
<https://joplins.net/articles/understanding-5-types-air-cleaners-purifiers>
3. Changing the air filter of a car
<https://www.artofmanliness.com/articles/how-to-change-your-cars-air-filter/>